

PRATT

Henry Pratt Company

Cone Valves



Valves for the 21st Century



A Tradition of Excellence

With the development of the first rubber seated butterfly valve more than 70 years ago, the Henry Pratt Company became a trusted name in the flow control industry, setting the standard for product quality and customer service. Today Pratt provides the following range of superior products to the water, wastewater and power generation industries.

BUTTERFLY VALVES: from 3" to 168"

RECTANGULAR VALVES: 1' x 1' to 14' x 16'

BALL VALVES —

RUBBER SEATED: from 4" to 60"

METAL SEATED: from 6" to 48"

PLUG VALVES: from 3" to 36"

VENTURI FLOW TUBES: from 1½" to 102"

DISMANTLING JOINTS: from 1½" to 216"

ENERGY DISSIPATING VALVES

A Commitment to Meeting The Customers' Needs

Henry Pratt valves represent a long-term commitment to both the customer and to a tradition of product excellence. This commitment is evident in the number of innovations we have brought to the industries we serve. In fact, the Henry Pratt Company was the first to introduce many of the flow control products in use today, including the first rubber seated butterfly valve, one of the first nuclear N-Stamp valves, and the bonded seat butterfly valve.

Innovative Products For Unique Applications

Though many of the standard valves we produce are used in water filtration and distribution applications, Pratt has built a reputation on the ability to develop specialized products that help customers to meet their individual operational challenges.

Creative Engineering for Fluid Systems

Pratt's ability to provide practical solutions to complex issues is demonstrated by the following case histories.

Valves Designed for Zebra Mussel Control

Pratt designed and manufactured a variety of large size circular and rectangular butterfly valves for use in recirculating hot water systems for zebra mussel control at several Midwestern fossil fuel power generating stations.

Earthquake Proof Valves

Pratt designed and manufactured hydraulically actuated valves for a water storage application so that the valves would automatically operate in the event of earthquakes. This led to the development of a valve that will withstand forces of up to 6g's.

Custom Actuation/ Isolation Valves

Pratt designed and manufactured valves that would isolate a working chamber in the event of a nuclear emergency during the decommissioning of armed nuclear warheads. The valves were able to close in a millisecond using specially designed Pratt electro-pneumatic actuators.

Valves Designed for Harsh Environments

Pratt designed and manufactured a 144" diameter butterfly valve for the emergency cooling system at a jet engine test facility. The valve was designed to supply water to help dissipate the tremendous heat generated by the engines during testing.

PRATT

Henry Pratt Company

Through experience, commitment and creative engineering, Pratt is uniquely suited to provide superior products for our customers' special needs. For more information, contact our corporate headquarters in Aurora, Illinois or your local Pratt sales representative listed on the inside back cover.



401 South Highland Avenue
Aurora, Illinois 60506-5563
<http://www.henrypratt.com/>
phone: 630.844.4000
fax: 630.844.4160
toll free: 877.436.7977

TABLE OF CONTENTS

INTRODUCTION	1
SCOPE OF LINE.....	1
DESIGN DETAILS: CONE VALVES.....	2
FEATURES & BENEFITS.....	3
COST EFFICIENCY: LOW HEADLOSS ADVANTAGE.....	3
OPERATION OF THE CONE VALVE	4-5
APPLICATIONS	6
SUGGESTED SPECIFICATION	7



Cone Valve

INTRODUCTION

In July 2001, the Henry Pratt Company acquired a cone valve product line from RMI Holland. RMI's history dates back to the 1800's as a leading manufacturer of valves and fittings with manufacturing facilities based in Holland.

By acquiring the RMI cone valve product line, Henry Pratt continues to expand our product offering to those customers who require specialty valves for applications with high velocity and pressure, to maintain constant pressure downstream, and to regulate flow. The cone valve is used in pump control, flow control, and shut off applications.

SCOPE OF LINE: CONE VALVE

- Available in sizes 8" to 48"
- Available in class 125 and 250 flanges
- Full bore circular valve body
- Ductile iron body
- Metal to metal seats
- Cast iron plug with bronze top and bottom bearings
- Available in class 150 and 250 psi pressure classes
- Cast iron cover with mounted operating mechanism
- Available with manual, pneumatic and electric actuators
- Other materials available upon request



48" Cone Valve in assembly

DESIGN DETAILS: CONE VALVES

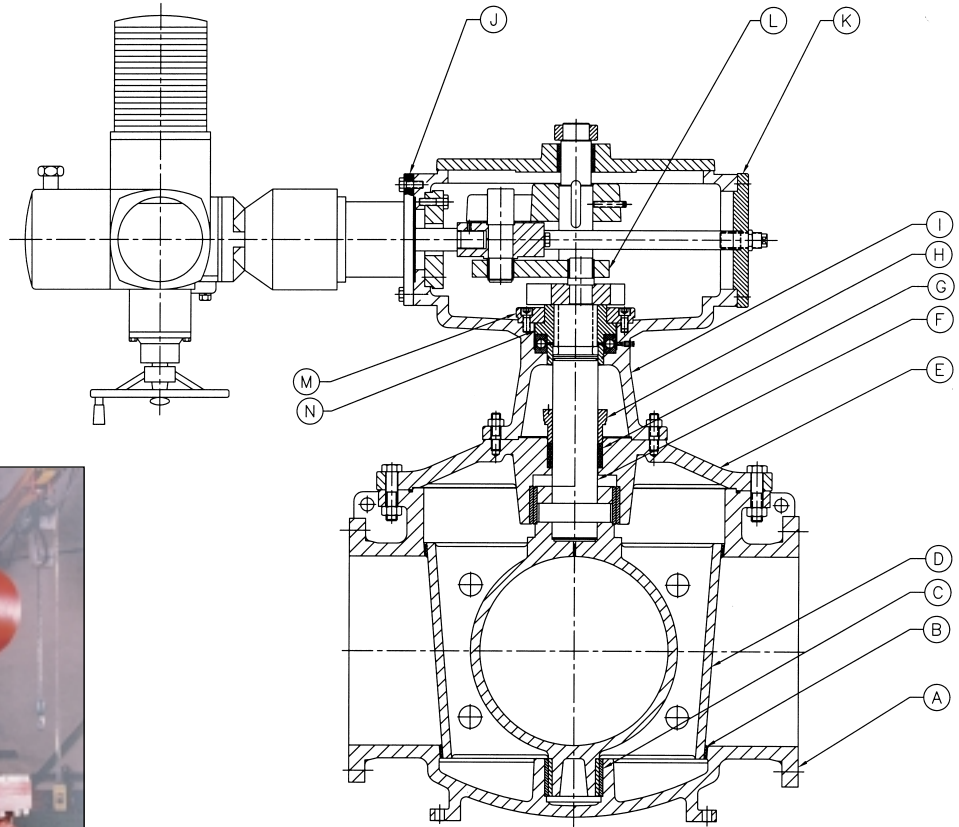

Mounting of the gearbox on top of the body.

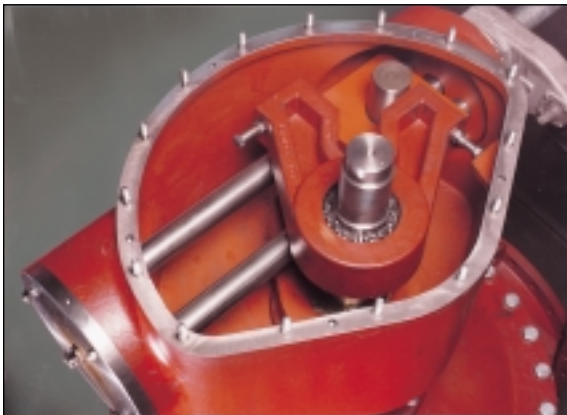

Inside of the gearbox.

ITEM NO.	DESCRIPTION	MATERIAL
A	Body	Ductile Iron
B	Body and Plug Seat	Monel or Nickel weld overlay
C	Bearing	Bronze
D	Plug	Ductile Iron
E	Cover	Ductile Iron
F	Shaft	304 Stainless Steel
G	Packing	PTFE impregnated Aramid
H	Gland	Cast Iron
I	Gearbox	Cast Iron
J	Mounting Flange for actuator	Steel
K	End Cover	Steel
L	Arm for Lift Nut Lever	Steel
M	Retaining Ring for Lift Nut	Ductile Iron
N	Lift Nut	Bronze

Other materials available upon request.

FEATURES & BENEFITS

Feature

Full bore opening

Metal to metal seats

High reliability

Low maintenance

Drop tight shut off

Custom made to specifications

Solid bronze bearings

Reduced pressure loss

Benefit

- The valve has a circular waterway through the plug and is full bore in the open position
- Seat replacement is not required
- Suitable for high velocities
- The design of the valve offers a long service life
- Maintenance is limited to lubrication of moving parts and replacement of packing in the stuffing box
- Accurate machining of the metal seats and plug ensures that each plug fits exactly into the mating body
- Pratt cone valves are designed to meet the customer's specific application
- Bronze construction offers longer trouble-free service
- Ability to handle wide pressure ranges
- Ideal for throttling applications

COST EFFICIENCY: LOW HEAD LOSS ADVANTAGE

In the open position the cone valve has a full bore opening through the valve. The flow is unobstructed which results in a headloss that is comparable to that of a straight pipe the same length and diameter.

Figure 1 illustrates the head loss between 5% and 70% of the valve opening angle. Precise flow is achieved by the smooth operation and long stroke of the valve actuator in rotating the valve plug.

The cone valve requires very little maintenance due to its high strength design, metal seats, and long service life. These features allow for a low yearly operating cost.



Plug with full bore opening and weld on metal seats.

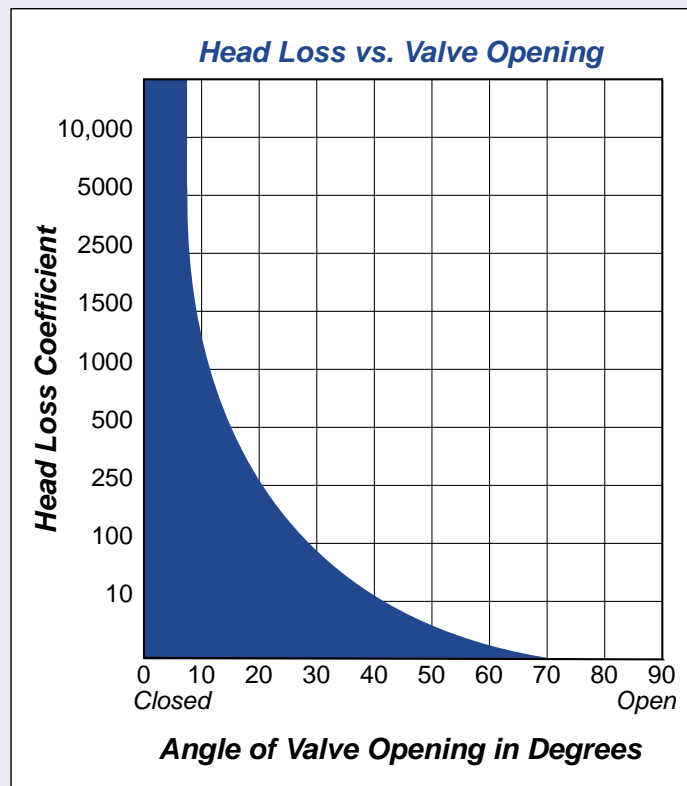
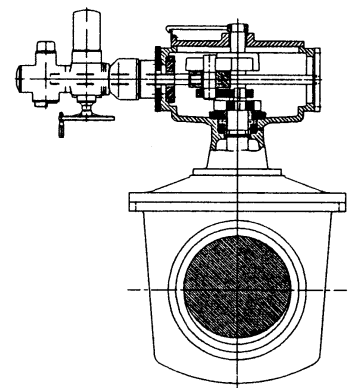
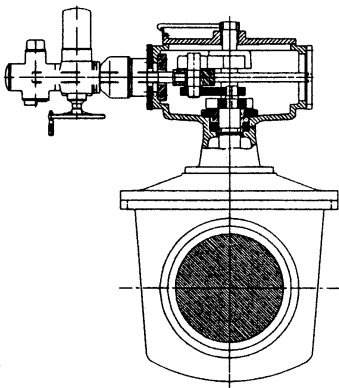
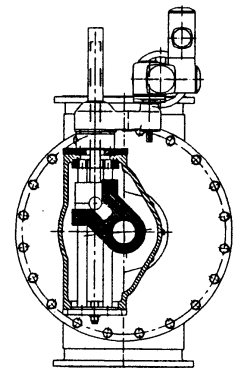
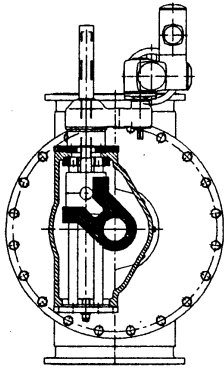

Figure 1: Cone valve characteristic curve

OPERATION OF THE CONE VALVE



Position 1

The valve is fully closed and the plug seats are in full contact with the seats of the body. This creates drop tight sealing of the valve.

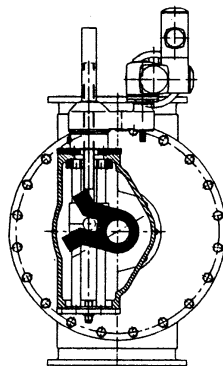

Position 2

By means of the lever the plug is lifted from its seats, to eliminate seat wear and decrease torque.

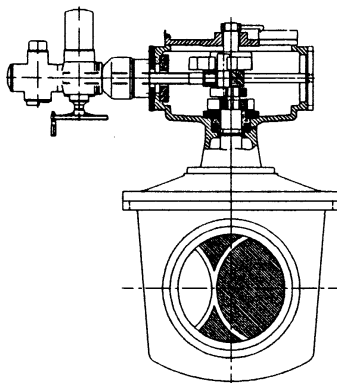

Position 3

By pushing against the rotator lever, the plug starts rotating, only in contact with the double bearing.

OPERATION OF THE CONE VALVE

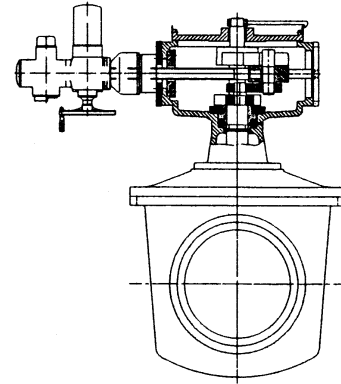
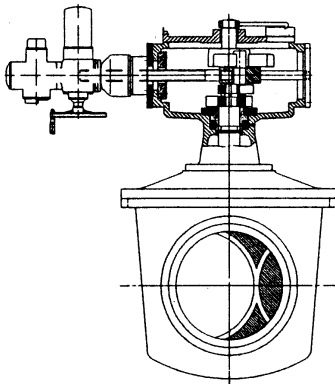
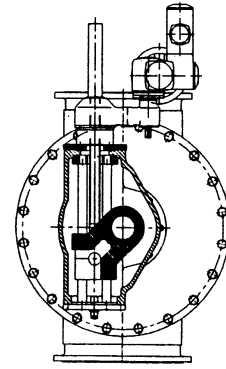
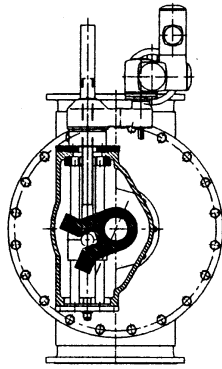

Position 4
The plug is still rotating, causing the opening to become larger.

Position 5
After the plug has reached the open position the plug reseats into the body. In the full open position the cone valve has very low headloss which can be compared with the headloss of a straight pipe with the same length and diameter.

APPLICATIONS

Pump Control Valve

- The Pratt Cone Valve is commonly used as a pump control valve. The unobstructed flow allows for very low headloss that results in low pumping costs. The valve also offers drop tight closure which prevents back flow. The valve has an uninterrupted operating cycle that allows for precise regulation of flow and prevention of water hammer.

Control Valve

- The Pratt Cone Valve is suitable to maintain constant flow or pressure downstream when used in combination with a flow pressure measuring device and a regulating actuator.

Shut Off Valve

- The Pratt Cone Valve offers a drop tight closure that is suitable for use to shut off a pipeline. The valve is commonly used in applications where high velocities and pressures can occur.



24" cone valves in operation since 1956.

SUGGESTED SPECIFICATION FOR CONE VALVES

Valve construction

The cone valve shall be of the conical plug type employing axial motion to unseat the plug, followed by a rotary motion to open or close the valve, and then followed by an axial motion to reseat the plug.

The valve shall be totally adapted to the flow conditions at the installation site. Cone valves shall be manufactured by Henry Pratt Company or approved equal.

Valve components

The valve shall consist essentially of four main parts:

- a. A valve body having waterway inlet and outlet diameters equal to the nominal size of the valve.
- b. A conical plug having a clear waterway, minimum diameter equal to the nominal size of the valve.
- c. A head cover to enclose the plug in the body.
- d. An operating mechanism mounted on the head cover.

Materials

Cone valves shall be furnished in ductile iron ASTM A536, suitable for the flow conditions at the installation site.

Body

The ductile iron body of the valve shall consist of a housing having flanged inlet and outlet waterways and a head flange opening. The head flange opening shall permit removal of the plug. Waterway flanges shall conform to client specifications. Inside the body of the valve, two monel or nickel seat rings shall be provided to engage the seat rings on the plug when the plug is seated. A bronze bearing shall be provided for the integrally cast plug trunnion.

Plug

The ductile iron plug shall have the shape of a frustrum of a cone with a clear waterway opening through it. The plug shall rotate on large diameter, bronze top and bottom bearings. The operating shaft shall be securely attached to the plug to transmit the lifting force and operating torque. The operating shaft shall be stainless steel. The plug shall be provided with monel or nickel seats to engage the monel or nickel seat rings on the body when seated in both open and closed position.

Head cover

The valve shall be provided with a ductile iron head cover to close the body head flange opening. The head cover shall make a registered connection with the valve body. A bronze bearing in an integrally cast trunnion shall be provided for the plug.

Actuation

The actuator shall be mounted on the head cover and shall be provided with a removable cover which shall permit inspection, adjustment and repair of the actuator. The actuator shall consist of a crosshead device which will lift, rotate and lower the plug. The crosshead shall travel in a straight line and shall operate through an independent link and lever arrangement. The lifting action shall be accomplished by means of a lift nut, and rotation shall be accomplished by means of a rotator lever. The operating shaft shall be of sufficient strength to withstand any stresses to which it may be subjected under the design operating conditions. The valve shall be provided with a position indicator which will at all times indicate the position of the valve plug.

Type of actuators

Manual actuator (handwheel or AWWA square nut), electric motor (local or remote controls), or cylinder per AWWA C540 standard for hydraulic or pneumatic control.

Testing

The valve shall be hydrostatically tested for strength at 2 times working (rated) pressure. The valve shall be hydrostatically tested for leak tightness at 1 time the designed working pressure.

Coating

Before coatings are applied, blast clean all unmachined areas to SSPC-SP10 standards. Coat surfaces with two coats of high solids epoxy paint or the engineer's recommended coatings.

Henry Pratt Company reserves the right to change parts and components to improve product performance.

HENRY PRATT COMPANY SALES OFFICES

EAST

BOSTON, MASSACHUSETTS
Technology Sales Assoc., Inc.
Phone: 508-695-6070
Fax: 508-699-7617

BUFFALO, NEW YORK
J. L. Moore, Inc.
Phone: 716-655-3433
Fax: 716-655-4440

NEW YORK, NEW YORK
Quality Controls, Inc.
Phone: 201-251-9000
Fax: 201-251-9507

PHILADELPHIA, PENNSYLVANIA
John B. Atherholt, Inc.
Phone: 610-828-4140
Fax: 610-828-4199

PITTSBURGH, PENNSYLVANIA
BissNuss, Inc.
Phone: 412-221-1200
Fax: 412-221-5952

YORK, PENNSYLVANIA
Henry Pratt Company
Eastern District Office
Phone: 717-747-0170
Fax: 717-741-6678

SOUTHEAST

ATLANTA, GEORGIA
TEMSCO, Inc.
Phone: 770-614-0194
Fax: 770-614-5992

BIRMINGHAM, ALABAMA
TEMSCO, Inc.
Phone: 205-988-0910
Fax: 205-988-0104

CHARLOTTE, NORTH CAROLINA
EW2 Environmental
Phone: 704-542-2444
Fax: 704-542-7003

JACKSON, MISSISSIPPI
Gulf States Engineering Co., Inc.
Phone: 601-922-1364
Fax: 601-922-1774

NASHVILLE, TENNESSEE
Southern Sales Co., Inc.
Phone: 615-254-0066
Fax: 615-254-0791

NEW ORLEANS, LOUISIANA
Gulf States Engineering Co., Inc.
Phone: 225-243-5500
Fax: 225-243-5508

ORLANDO, FLORIDA
Fluid Control Specialties, Inc.
Phone: 407-831-9938
Fax: 407-831-7268

RICHMOND, VIRGINIA
Engineered Systems and Products, Inc.
Phone: 804-271-7200
Fax: 804-271-8317

WEST

DENVER, COLORADO
Pipestone Industrial Co., Inc.
Phone: 303-771-2300
Fax: 303-771-2396

GREAT FALLS, MONTANA
Goble Sampson Associates
Phone: 406-965-2536
Fax: 406-965-2520

KAILUA, HAWAII
CBC Inc.
Phone: 808-263-8838
Fax: 808-261-4778

SALT LAKE CITY, UTAH
W-Cubed
Phone: 801-466-3819
Fax: 801-466-3850

SAN FRANCISCO, CALIFORNIA
JM Squared Associates
Phone: 925-798-2500
Fax: 925-798-7737

SCOTTSDALE, ARIZONA
Henry Pratt Company
Western District Office
Phone: 480-391-0564
Fax: 480-451-1472

SOUTHERN CALIFORNIA
Southwest Valve & Equipment, Inc.
Phone: 714-832-1090
Fax: 714-832-1091

SEATTLE, WASHINGTON
Beaver Equipment Company
Phone: 425-451-3862
Fax: 425-454-6531

SOUTHWEST

DALLAS, TEXAS
Manufactured Valve Products, Inc.
Phone: 972-681-2200
Fax: 972-681-0066

HOUSTON, TEXAS
Scruggs Company
Phone: 713-649-2776
Fax: 713-649-1975

PHOENIX, ARIZONA
C.J. Raleigh and Associates
Phone: 623-972-9238
Fax: 623-972-9250

MIDWEST

CHICAGO, ILLINOIS
Henry Pratt Company
Central District Office
Phone: 630-844-4000
Fax: 630-844-4160

CLEVELAND, OHIO
BissNuss, Inc.
Phone: 440-871-8394
Fax: 440-871-2526

CINCINNATI, OHIO
BissNuss, Inc.
Phone: 513-860-1630
Fax: 513-860-9555

DETROIT, MICHIGAN
Peterson and Matz, Inc.
Phone: 248-476-3204
Fax: 248-476-3445

INDIANAPOLIS, INDIANA
Colley & Associates, Inc.
Phone: 317-254-1001
Fax: 317-251-3272

KANSAS CITY, KANSAS
H*E Engineered Equipment, Co.
Phone: 913-236-9494
Fax: 913-236-9497

MILWAUKEE, WISCONSIN
Energenecs
Phone: 262-377-6360
Fax: 262-377-1515

MINNEAPOLIS, MINNESOTA
Plant & Flanged Equipment Co.
Phone: 763-792-3870
Fax: 763-792-3876

OMAHA, NEBRASKA
Bert Gurney & Associates, Inc.
Phone: 402-551-7995
Fax: 402-553-5879

ST. LOUIS, MISSOURI
Van Devanter Engineering Co.
Phone: 636-343-8880
Fax: 636-343-1720

TULSA, OKLAHOMA
H*E Engineered Equipment Co.
Phone: 918-251-2121
Fax: 918-251-1051

Contact Pratt headquarters for sales representative offices
serving the power and international market places.

PRATT

MISSION STATEMENT

To design and manufacture valves for fluid service that
exceed our customers' quality and delivery expectations.

Pratt History >

Engineering >

Products >

Specifications >

<http://www.henrypratt.com/>

PRATT PRODUCT GUIDE

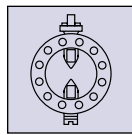

Model 2FI

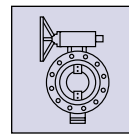

Triton HP250

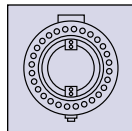

Triton XR70

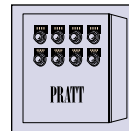

Control Systems

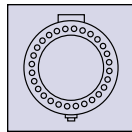

Triton XL

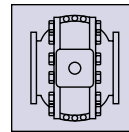

Metal Seated Ball Valve

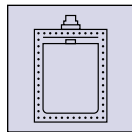

Rectangular

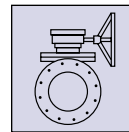

Plug Valve

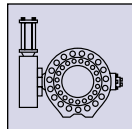

Rubber Seated Ball Valve

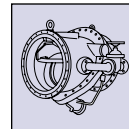

Tilting Disc Check Valve

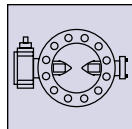

Groundhog Valve

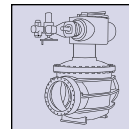

Cone Valve

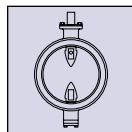

Monoflange MKII

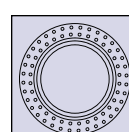

Energy Dissipating Valves

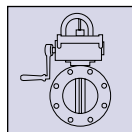

Indicating Butterfly Valve
UL & FM approved

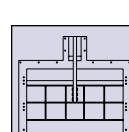

Sluice Gate

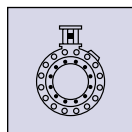

N-Stamp Nuclear Butterfly Valve

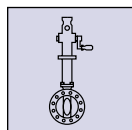

PIVA Post Indicating Valve Assembly
UL & FM approved

PRATT

Henry Pratt Company
401 South Highland Avenue
Aurora, Illinois 60506-5563
Toll Free 877-436-7977
630-844-4000
Fax 630-844-4160
www.henrypratt.com

©2002 Henry Pratt Company
Printed in the U.S.A.
CONE-0402

