

# PRATT

Henry Pratt Company

*Fixed Cone*

*Valve*

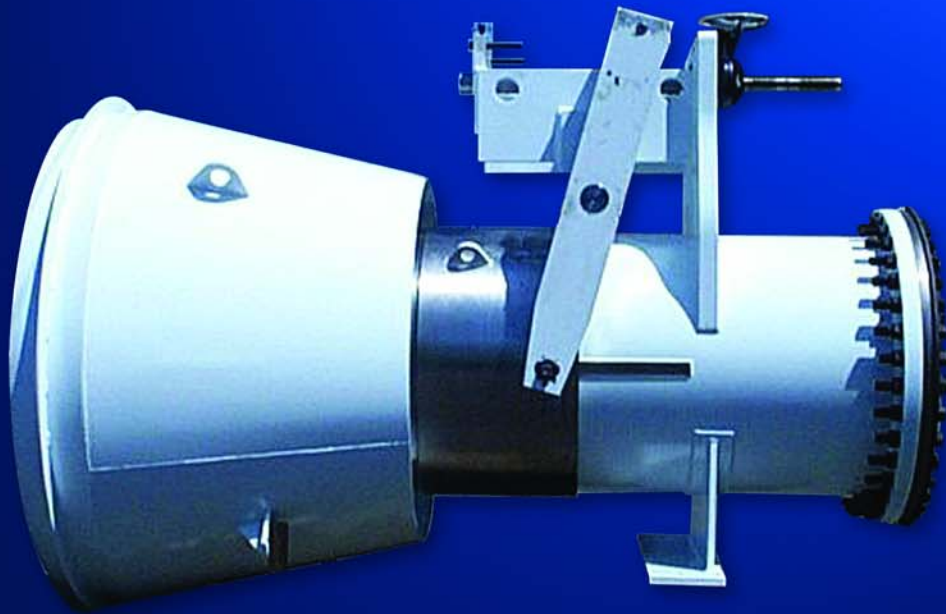

*Valves for the 21st Century*



## A Tradition of Excellence

With the development of the first rubber seated butterfly valve more than 70 years ago, the Henry Pratt Company became a trusted name in the flow control industry, setting the standard for product quality and customer service. Today Pratt provides the following range of superior products to the water, wastewater and power generation industries.

**BUTTERFLY VALVES:** from 3" to 162"

**RECTANGULAR VALVES:** 1' x 1' to 14' x 16'

**BALL VALVES —**

**RUBBER SEATED:** from 4" to 60"

**METAL SEATED:** from 6" to 48"

**PLUG VALVES:** from 1/2" to 36", 3 ways

**HYDRAULIC CONTROL SYSTEMS**

**VALVE CONTROLS**

**ENERGY DISSIPATING VALVES  
AND FIXED ENERGY DISSIPATERS**

**CONE VALVES**

**CHECK VALVES**

## A Commitment to Meeting The Customers' Needs

Henry Pratt valves represent a long-term commitment to both the customer and to a tradition of product excellence. This commitment is evident in the number of innovations we have brought to the industries we serve. In fact, the Henry Pratt Company was the first to introduce many of the flow control products in use today, including the first rubber seated butterfly valve, one of the first nuclear N-Stamp valves, and the bonded seat butterfly valve.

## Innovative Products For Unique Applications

Though many of the standard valves we produce are used in water filtration and distribution applications, Pratt has built a reputation on the ability to develop specialized products that help customers to meet their individual operational challenges.

## Creative Engineering for Fluid Systems

Pratt's ability to provide practical solutions to complex issues is demonstrated by the following case histories.

### Earthquake Proof Valves

Pratt designed and manufactured hydraulically actuated valves for a water storage application so that the valves would automatically operate in the event of earthquakes. This led to the development of a valve that will withstand forces of up to 6g's.

### Custom Actuation/ Isolation Valves

Pratt designed and manufactured valves that would isolate a working chamber in the event of a nuclear emergency during the decommissioning of armed nuclear warheads. The valves were able to close in a millisecond using specially designed Pratt electro-pneumatic actuators.

### Valves Designed for Harsh Environments

Pratt designed and manufactured a 144" diameter butterfly valve for the emergency cooling system at a jet engine test facility. The valve was designed to supply water to help dissipate the tremendous heat generated by the engines during testing.

# PRATT

Henry Pratt Company

**Through experience, commitment and creative engineering, Pratt is uniquely suited to provide superior products for our customers' special needs. For more information, contact our corporate headquarters in Aurora, Illinois.**

# PRATT

Henry Pratt Company

401 South Highland Avenue  
Aurora, Illinois 60506-5563  
<http://www.henrypratt.com/>  
phone: 630.844.4000  
fax: 630.844.4160  
toll free: 877.436.7977



## FIXED CONE VALVE

### TABLE OF CONTENTS

INTRODUCTION TO ENERGY DISSIPATING VALVES.....	1
SCOPE OF THE LINE: MODEL 117 .....	1
DESIGN DETAILS .....	2
FEATURES AND BENEFITS .....	2
CONE VALVE APPLICATIONS .....	3
SIZING A MODEL 117 CONE VALVE .....	3
MODEL 117 VALVE SPECIFICATIONS.....	4

## INTRODUCTION TO ENERGY DISSIPATING VALVES

Over the years, Pratt has maintained a commitment to product innovation by designing water control valves that improve our clients' processes and reduce their operation and maintenance costs. Our products are developed to meet and surpass even the most difficult specifications.

By adding sleeve valves, fixed cone valves, and energy dissipaters to our product line, Pratt continues to expand our offering to those customers who require specialty valves for applications where there is zero back pressure, cavitation or high flow rates.

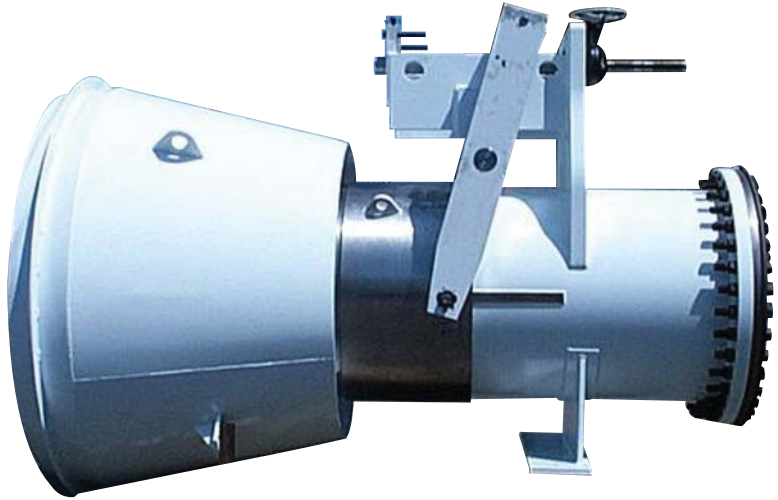

*42" Fixed Cone Valve with hood*

### SCOPE OF THE LINE: MODEL 117 FIXED CONE VALVE

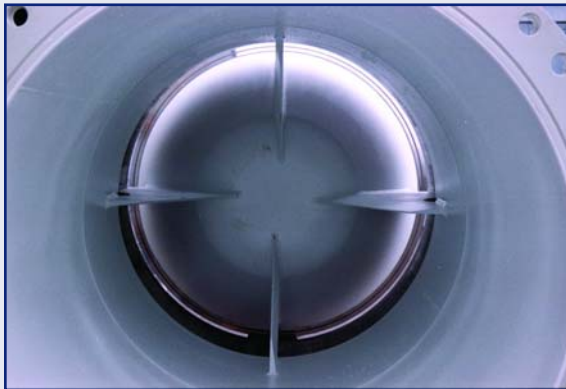

*Contoured ribs on the internal of Model 117*

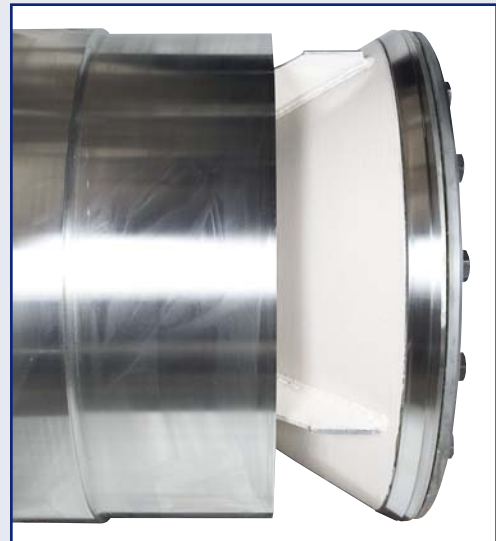

*Metal-to-metal seat without hood*

- Available in sizes 6 inches and larger
- Welded steel or stainless steel construction
- Nitronic 60 drip tight seat
- Contoured ribs with Nitronic 60 overlay
- Epoxy coated interior
- Available with or without hood

## DESIGN DETAILS: MODEL 117 FIXED CONE VALVE

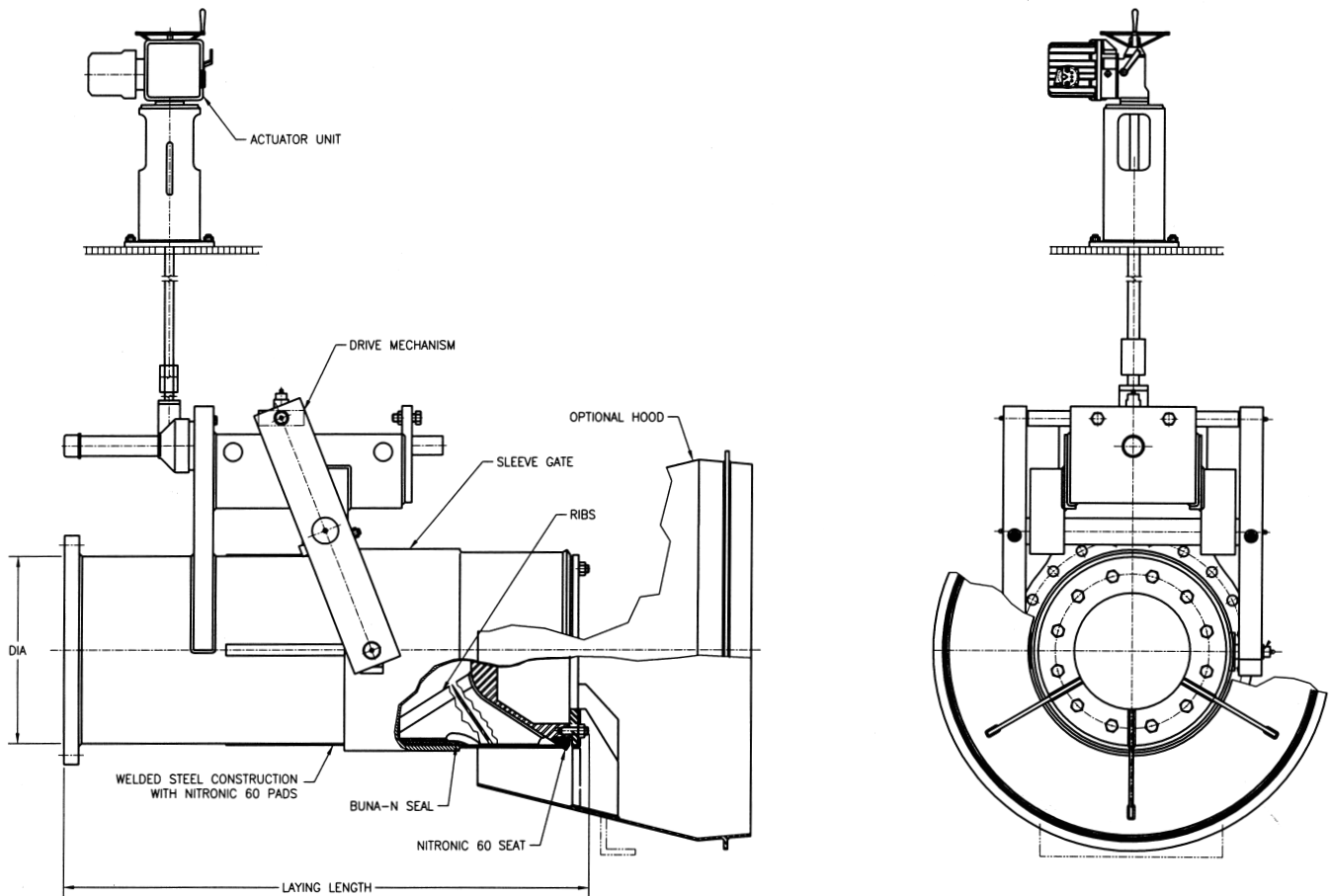

### FEATURES AND BENEFITS: MODEL 117 FIXED CONE VALVE

#### FEATURE

Nitronic 60 stainless steel seat

Silastic J floating seat system

Contoured cone and rib design

Circular flow pattern

Optional hood

Ease of maintenance

#### BENEFIT

- Self-aligning
- Gall, abrasion, and erosion resistant

- Provides self alignment seat
- Drip tight shut-off

- Provides vibration free operation
- Prevents pressure fluctuations

- Uniform flow pattern without turndown limitations

- Offers flow discharge into confined areas
- Can be secured to the fixed cone or outlet structure

- Can be performed while the valve is in line

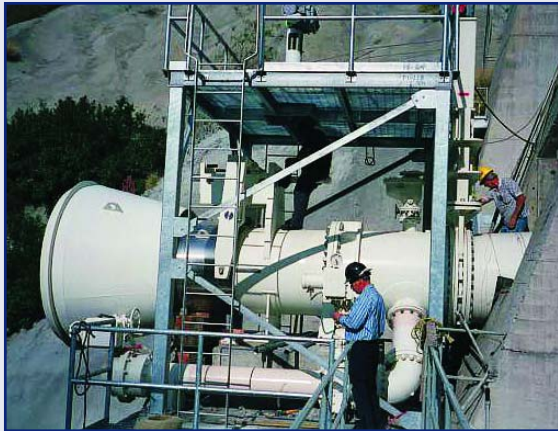

42" Fixed Cone Valve  
in a flood control application.

## CONE VALVE APPLICATIONS

The Model 117 Fixed Cone Valve is used to regulate flow from dams and reservoirs. It is a free discharge valve that is commonly used as a turbine bypass valve, reservoir drain, or continuous discharge flow control valve.

The Model 117 has a fixed cone with contoured ribs that eliminate the vibration problems associated with other fixed cone designs. Flow is controlled by movement of an external stainless steel gate which has a drip tight metal-to-metal shut off against the Nitronic 60 seat.

When discharging into the atmosphere, the jet spreads out in a wide cone angle and breaks up into a fine spray. If containment of the jet is desired, a hood can be installed which concentrates the flow.

## SIZING A MODEL 117 FIXED CONE VALVE

To determine the valve size it is necessary to calculate the desired flow rate. The flow rate can be calculated as follows:

$$Q = C_d \times (2gH)^{1/2} \times A$$

- Q = Flow (cfs)
- $C_d$  = Discharge Coefficient (.86 max)
- A = Cross-sectional Area of the pipe ID (square feet)
- g = 32.17 ft/s<sup>2</sup>
- H = Upstream Head (feet)

- For velocities 0-50 fps maximum epoxy coated carbon steel construction is provided
- For velocities 51-100 fps maximum stainless steel construction is provided

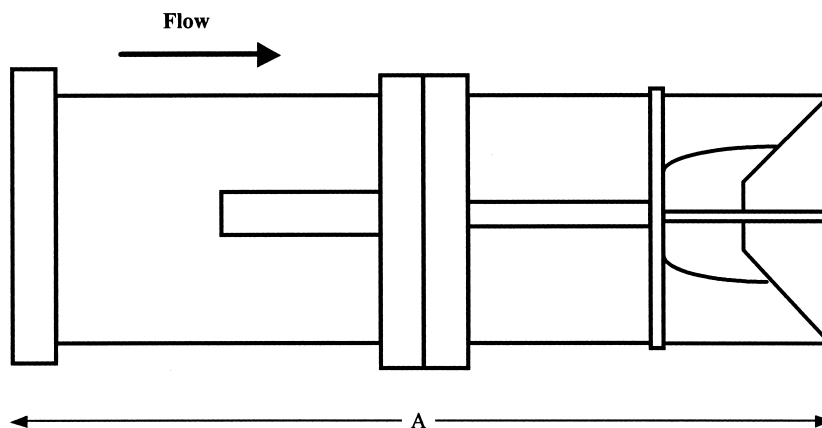

Dimension "A" can be approximated by  $A = 3.0 \times \text{valve diameter}$ .

Note: All dimensions are approximate and should be used for estimating purposes only. Exact dimensions will be supplied on submittal drawings.

# SUGGESTED SPECIFICATION FOR FIXED CONE VALVES

## General Specifications

The fixed cone valve shall be as manufactured by the Henry Pratt Company or approved equal.

## Design

The valve shall be designed as a free discharging fixed cone valve capable of operating throughout its range without cavitation or vibration. The valve shall be metal-to-metal seated achieving drip tight shut off.



*Free discharging fixed cone valve*

## Valve Body

The body will be of a cylindrical design with an upstream flange for connecting to a conduit/pipe. The downstream end will contain a floating metal conical seat ring designed to isolate it from stresses that can cause distortion. The body will incorporate four vanes designed as stabilizers to allow the valve gate to travel from open to closed without vibration. The conical seat will be field replaceable without removing the valve from the line. The body will contain a rear seal groove to seal the sleeve gate and prevent leakage during operation.

## Valve (Sleeve) Gate

The sleeve gate is cylindrical and uses a linear motion to open and close the valve. Seating is achieved by an internal sealing surface which contacts the floating body seat at the end of its stroke.

## Hoods

When a hood is required to direct the discharge flow stream it should be attached to the valve body. Hoods attached to the valve gate (sleeve) shall not be allowed.

## Actuation

Fixed cone valves can be actuated using either electric motors, hydraulic cylinders or manual actuators. The chosen method shall be sized to perform the function for which it is required. Actuators shall conform to AWWA C540.

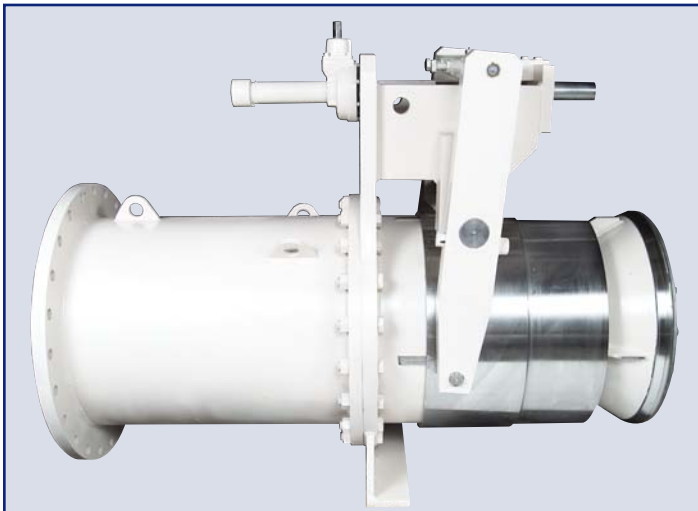

*Fixed Cone Valve without hood with Rotary Drive System*

## Testing

The valve shall be hydrostatically tested at two times working (rated) pressure for 30 minutes and shall show no sign of leakage at the welded areas or through the body. The body and gate (sleeve) seat when in the closed position shall be drip tight.

## Painting

Before coatings are applied, blast clean all unmachined areas to SSPC-SP10 standards. Coat surfaces with two coats of high solids epoxy paint or the engineer's recommended coatings.

Pratt History >

Engineering >

Products >

Specifications >

<http://www.henrypratt.com/>

### PRATT PRODUCT GUIDE

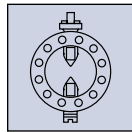

Model 2FI

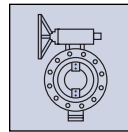

Triton® HP250

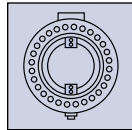

Triton® XR70



Control Systems

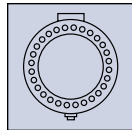

Triton® XL

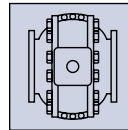

Metal Seated Ball Valve

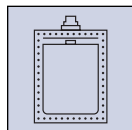

Rectangular

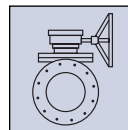

Plug Valve

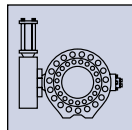

Rubber Seated Ball Valve

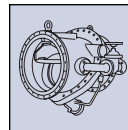

Tilting Disc Check Valve

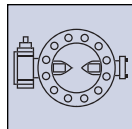

Groundhog® Valve

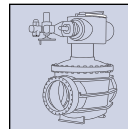

Cone Valve

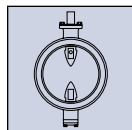

Monoflange MKII

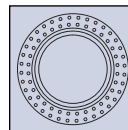

Sleeve Valve

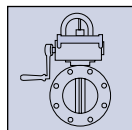

Indicating Butterfly Valve  
UL & FM approved

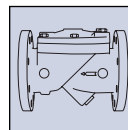

Check Valve

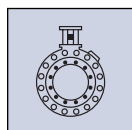

N-Stamp Nuclear Butterfly Valve

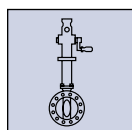

PIVA Post Indicating Valve Assembly  
UL & FM approved



#### Henry Pratt Company

401 South Highland Avenue  
Aurora, Illinois 60506-5563  
Toll Free 877-436-7977  
630-844-4000  
Fax 630-844-4160  
[www.henrypratt.com](http://www.henrypratt.com)  
ISO 9001: 2000 Certified

©2005 Henry Pratt Company  
Printed in the U.S.A.  
FC-1005

