

# PRATT

Henry Pratt Company

*Metal Seated*

*Ball Valve*

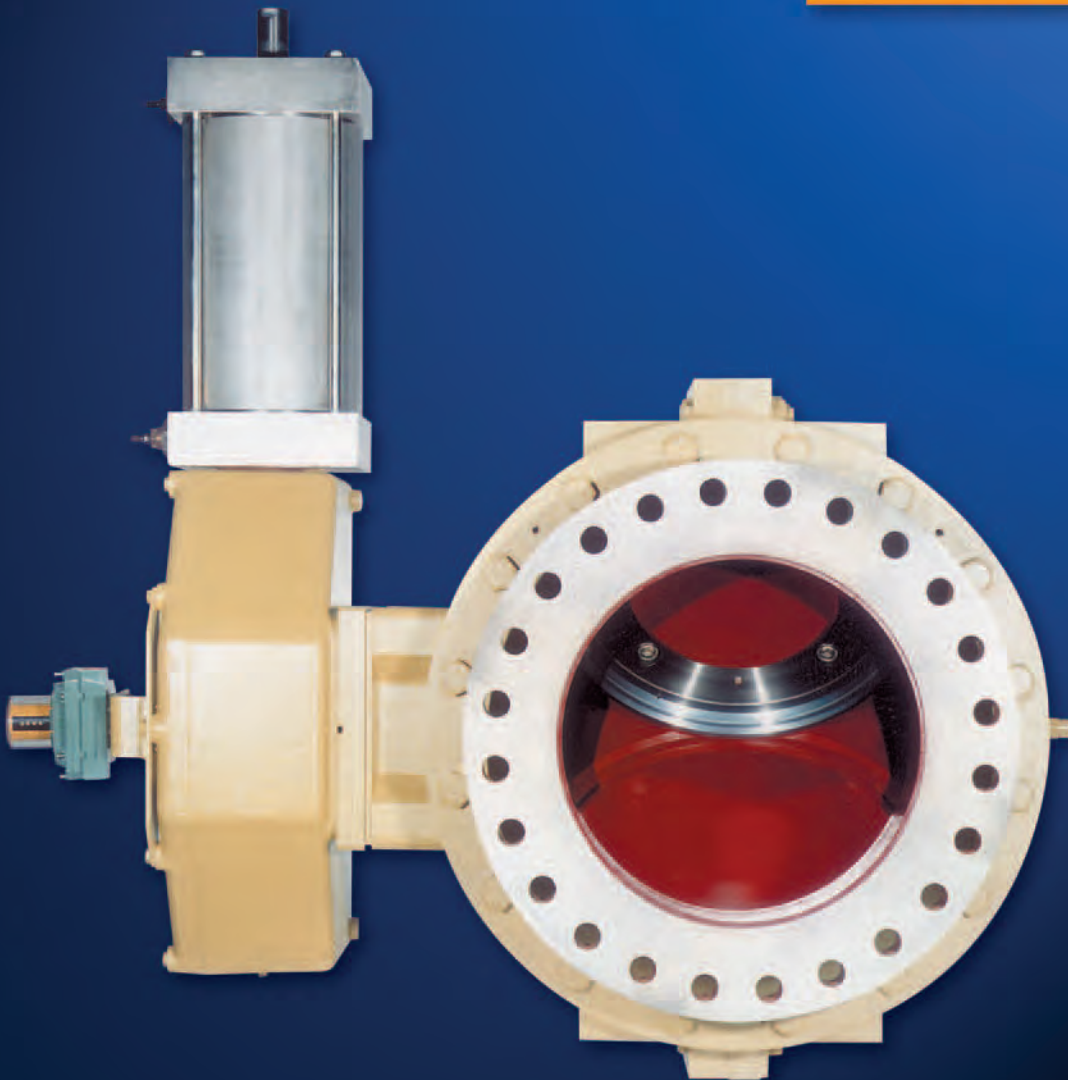

*Valves for the 21st Century*



## A Tradition of Excellence

With the development of the first rubber seated butterfly valve more than 70 years ago, the Henry Pratt Company became a trusted name in the flow control industry, setting the standard for product quality and customer service. Today Pratt provides the following range of superior products to the water, waste water and power generation industries.

**BUTTERFLY VALVES:** from 3" to 162"

**RECTANGULAR VALVES:** 1' x 1' to 14' x 16'

**BALL VALVES —**

**RUBBER SEATED:** from 4" to 60"

**METAL SEATED:** from 6" to 48"

**PLUG VALVES:** from 1/2" to 36", 3 ways

**HYDRAULIC CONTROL SYSTEMS**

**VALVE CONTROLS**

**ENERGY DISSIPATING VALVES**

**AND FIXED ENERGY DISSIPATORS**

**CONE VALVES**

**CHECK VALVES**

## A Commitment to Meeting The Customers' Needs

Henry Pratt valves represent a long-term commitment to both the customer and to a tradition of product excellence. This commitment is evident in the number of innovations we have brought to the industries we serve. In fact, the Henry Pratt Company was the first to introduce many of the flow control products in use today, including the first rubber seated butterfly valve, one of the first nuclear N-Stamp valves, and the bonded seat butterfly valve.

## Innovative Products For Unique Applications

Though many of the standard valves we produce are used in water filtration and distribution applications, Pratt has built a reputation on the ability to develop specialized products that help customers to meet their individual operational challenges.

## Creative Engineering for Fluid Systems

Pratt's ability to provide practical solutions to complex issues is demonstrated by the following case histories:

### ■ Earthquake Proof Valves

Pratt designed and manufactured hydraulically actuated valves for a water storage application so that the valves would automatically operate in the event of earthquakes. This led to the development of a valve that will withstand forces of up to 6g's.

### ■ Custom Actuation/Isolation Valves

Pratt designed and manufactured valves that would isolate a working chamber in the event of a nuclear emergency during the decommissioning of armed nuclear warheads. The valves were able to close in a millisecond using specially designed Pratt electro-pneumatic actuators.

### ■ Valves Designed for Harsh Environments

Pratt designed and manufactured a 144" diameter butterfly valve for the emergency cooling system at a jet engine test facility. The valve was designed to supply water to help dissipate the tremendous heat generated by the engines during testing.



**Through experience, commitment and creative engineering, Pratt is uniquely suited to provide superior products for our customers' special needs. For more information, contact our corporate headquarters in Aurora, Illinois.**

## TABLE OF CONTENTS

INTRODUCTION .....	2
SCOPE OF LINE .....	3
FEATURES AND BENEFITS .....	3
SUGGESTED SPECIFICATIONS .....	4
DIMENSIONAL DATA	
150# METAL SEATED BALL VALVE .....	6
300# METAL SEATED BALL VALVE .....	7
ACTUATOR DIMENSIONAL DATA .....	8
DESIGN DETAILS: METAL SEATED BALL VALVE .....	8
BALL VALVE INSTALLATION ADVANTAGES	
LOWER INSTALLATION COST .....	9
LOWER OPERATING COST .....	9
TYPICAL PUMP/CHECK SURGE CONTROL SYSTEM.....	10
CONTROL APPLICATIONS .....	12
CHARACTERIZED CLOSURE .....	12
SHUTOFF/BLOCK VALVE SERVICE .....	12

## INTRODUCTION

For more than seventy years, the Henry Pratt Company has provided superior quality valves for pump control applications. Continuing this tradition of excellence, in 1991 Pratt introduced a metal seated ball valve to the municipal water and waste water marketplace. Further design developments resulting from the use of state-of-the-art software technology have led to improvements in the seat geometry and additional features to help propel Pratt into the forefront of metal seated ball valve technology.

The Pratt metal seated ball valve is constructed of the highest quality materials and workmanship, backed by decades of engineering and manufacturing know-how. Designed to meet or exceed AWWA C507 standards for ball valves, the Pratt metal seated ball valve provides the following benefits to the user.



## SCOPE OF LINE: METAL SEATED BALL VALVES

**Sizes:** 6 through 48 inches

**Pressure Class:** ANSI B16.1 CL.125 or CL.250

**Pressure Ratings:** 150, 250, or 300 psig

**Metal Seated:** Single-seated or double-seated

**Shafts Available:**

- ASTM A564
- Type 630 H1150 (17-4 PH)
- Stainless Steel

**Actuators Available:**

- Manual
- Cylinder
- Motor

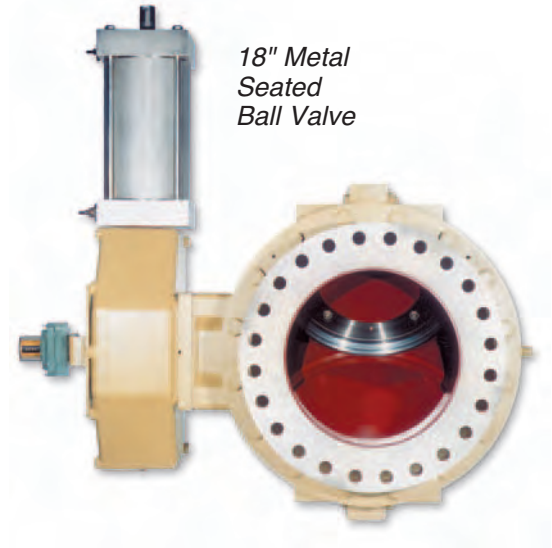

FEATURE	BENEFIT
Pressure Assisted Metal Seat	<ul style="list-style-type: none"> <li>• Long life</li> <li>• No scraping, galling, or wedging during operation</li> <li>• Field adjustable</li> </ul>
Cast Ductile Iron Construction	<ul style="list-style-type: none"> <li>• Rated for 300 PSIG service*</li> <li>• Superior impact resistance</li> <li>• Higher strength than cast iron</li> </ul>
Trunnion Mounted Ball	<ul style="list-style-type: none"> <li>• Resists deflection</li> <li>• Allows smooth operation</li> </ul>
100% Full Port Body Design	<ul style="list-style-type: none"> <li>• Head loss equal to an equivalent length of straight pipe</li> <li>• Lower pumping requirements result in reduced power costs</li> <li>• Operates equally well at high or low velocities without cavitation</li> </ul>
Self Flushing Operation	<ul style="list-style-type: none"> <li>• Ideal for waste water pumping applications</li> <li>• Suitable for continuous throttling applications</li> </ul>

\* Consult factory for higher pressures

# SUGGESTED SPECIFICATION FOR AWWA C507 METAL SEATED BALL VALVES

## General

The ball valve shall be metal to metal seated with flanged ends, drilled to the applicable ANSI B16.1 standard Class 125 or 250. Valve shall have a clear unobstructed waterway, which will result in no significant head loss, when the valve is in the full open position.

The valve shall be drop tight and meet or exceed the AWWA

C507-(latest revision) inspection and testing standard. The valve shall be single seated for pump control and rated at 150, 250, or 300 psi. The valve shall be as manufactured by “**HENRY PRATT CO.**”

The valve shall consist of a body, ball and operating unit (actuator).

## Body

The body shall be cast ductile iron ASTM A 536 grade 65-45-12 having an inlet and outlet flanged waterway equal to the required valve size. Flanges shall be flat-faced and machined parallel to each other to within .005 inch. Valve body shall have both a drain and vent hole drilled and tapped.

The body shall have bronze bearings installed in each half accurately located in the center of the housing to receive the trunnion bearings on the ball and place the ball in the central position. The bearing load shall not exceed 2000 lb/sq. inch at 250 psi differential pressure. The body seat shall be Monel electronically fused to the base metal, then accurately machined to form the seating seal, or other C507-(latest revision) approved materials. The body seat shall not protrude into the waterway.

*20" Metal Seated Ball Valves in Pump Control Service*



## Ball

The ball shall be cast ductile iron ASTM A 536 grade 65-45-12. It shall have integrally cast trunnions which will be bronze-bushed. One trunnion holds the operating shaft which passes through a packing seal area and connects to the actuator. To prevent leakage around the shaft, V-Type packing is installed to form a seal. The ball seat shall be stainless steel 300 series. It shall be a pressure-assisted design and by using an offset on the body and ball, the seats will only be in contact at the actual point of closing. The seat is connected to the ball by means of a stainless steel mounting ring which is securely attached and pinned into position after the correct setting has been attained. Seats threaded directly on to the ductile iron ball shall not be acceptable.

Valve seat assembly shall be fully adjustable and replaceable in the field without removing the valve from the line. The ball seat shall be located at the top, when the valve is in the open position.

## **Valve Actuators**

Valve actuators shall conform to the operating requirements of AWWA Standard C507-(latest revision) and shall be designed to hold the valve in any intermediate position between full open and fully closed without creeping or fluttering.

- A. Manual actuators shall be of the travelling nut, self-locking type and shall be equipped with mechanical stop limiting devices to prevent over-travel of the ball in the open or closed positions. Actuators shall be fully enclosed and designed to produce specified torque with a maximum pull of 80 lbs. on a handwheel or a maximum input of 150 ft.-lbs. on operating nuts. Actuator components shall withstand an input torque of 450 ft.-lbs. at extreme actuator positions without damage.
- B. Cylinder actuators shall move the valve to any position from full open to fully closed when a maximum of \_\_\_\_\_ psi or a minimum of \_\_\_\_\_ psi is applied to the cylinder. All wetted parts of the cylinder shall be corrosion resistant and cylinder rods shall be chromium-plated stainless steel. Cylinders furnished with enclosed operating mechanisms shall have all wetted parts constructed of non-metallic materials except the cylinder rod which shall be chromium-plated stainless steel. Rod seals shall be of the non-adjustable wear-compensating type. A rod wiper for removing deposits inside the cylinder shall be provided in addition to the external dirt wiper. Cylinder actuators of this type shall be Pratt MDT with Duracyl cylinder.

## **Bearings**

Bearings for ball and body trunnions shall be bronze of dissimilar hardness as per AWWA C507-(latest revision) standard to prevent galling or binding. Self-lubricating Teflon reinforced would also be acceptable.

## **Shafts**

Acceptable materials for valve shafts shall be: ASTM A 564 Type 630, H1150 (17-4 PH) Stainless Steel, or other C507-(latest revision) approved materials.

## **Valve Testing**

All ball valves shall be subjected to hydrostatic, shop leakage and performance tests as specified in AWWA Standard C507-(latest revision). Maximum seat leakage allowance 1 fl. oz. per diameter inch per hour as per AWWA C507-(latest revision).

## **Valve Painting**

All internal ductile iron surfaces, except finished or bearing surfaces, shall be shop painted, and AWWA C550.

All exterior steel or cast or ductile iron surfaces of each valve, except finished or bearing surfaces, shall be shop painted with one or more coats of Alkyd primer.

# DIMENSIONAL DATA: 150# METAL SEATED BALL VALVE

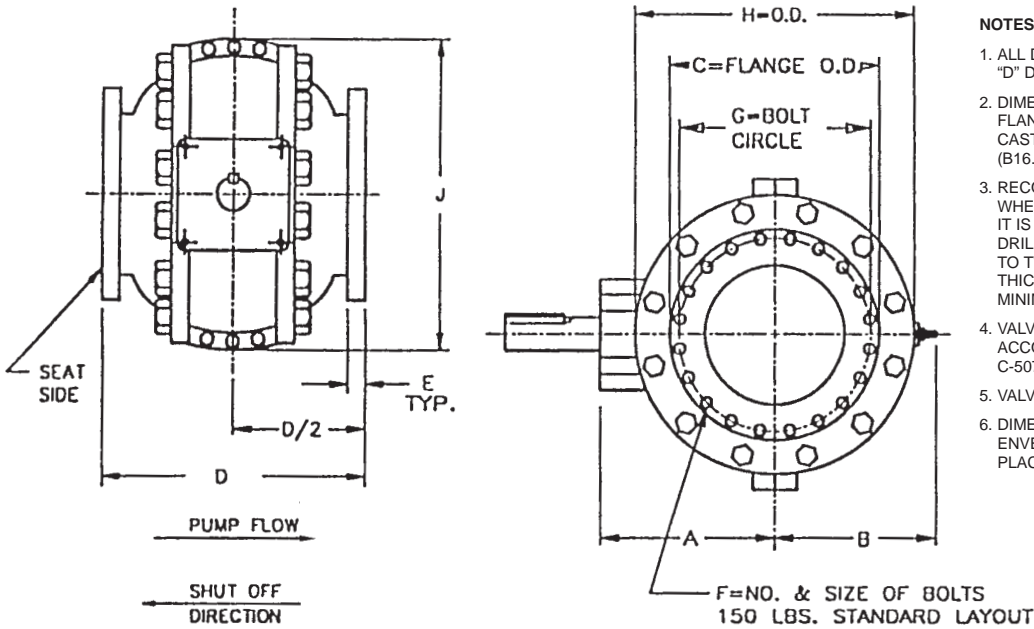

**NOTES:**

1. ALL DIMENSIONS SHOWN IN INCHES. "D" DIMENSION  $\pm 1/8$ ".
2. DIMENSIONS AND DRILLING OF END FLANGES CONFORM TO THE AMERICAN CAST IRON FLANGE STANDARDS, CLASS 125 (B16.1).
3. RECOMMENDATIONS FOR MATING FLANGES WHERE INSULATING BUSHINGS ARE USED, IT IS NECESSARY THAT BOLT HOLES BE DRILLED OVERSIZE BY AN AMOUNT EQUAL TO TWO TIMES THE INSULATING SLEEVE THICKNESS TO MAINTAIN THE SAME MINIMUM CLEARANCE FOR BOLTS.
4. VALVES MANUFACTURED AND TESTED IN ACCORDANCE WITH AWWA SPECIFICATIONS C-507-(LATEST REVISION).
5. VALVE ROTOR SHOWN IN OPEN POSITION.
6. DIMENSIONS GIVEN ARE NOMINAL ENVELOPE AND SHOULD NOT BE USED IN PLACE OF CERTIFIED DRAWINGS.

Valve Size	A	B	C	D	E	F	G	H	J
6	10	12	11	14	1	8x3/4	9-1/2	18	15-3/8
8	12-3/8	10	13-7/8	15	1-1/8	8x3/4	11-3/4	18-5/8	20-1/2
10	13-3/4	11-1/4	16-3/8	18-1/2	1-1/4	12x7/8	14-1/4	21-9/16	22
12	15-1/8	12-5/8	19-3/8	19-1/2	1-1/4	12x7/8	17	24-1/4	26-1/4
14	16-5/8	14-1/8	21-3/8	22-1/8	1-3/8	12x1	18-3/4	27-1/4	31-1/4
16	17-7/8	15-5/8	23-7/8	25	1-1/2	16x1	21-1/4	29-11/16	34-1/2
18	19-1/4	17-5/8	25-3/8	28-1/2	1-5/8	16x1-1/8	22-3/4	32-7/16	37-3/4
20	20-3/8	17-3/4	27-7/8	30	1-3/4	20x1-1/8	25	34-11/16	40-3/4
24	23-1/4	22	32-3/8	35-3/8	1-7/8	20x1-1/4	29-1/2	40-9/16	46-1/2
30	28-1/4	26-5/8	39-1/8	44-1/4	2-1/8	28x1-1/4	36	48-1/4	57-1/8
36	32-3/4	31-5/8	46-3/8	53	2-3/8	32x1-1/2	42-3/4	56-3/8	66-1/4
42	37-11/16	35-7/8	53-3/8	59-1/2	2-5/8	36x1-1/2	49-1/2	63-1/8	77-1/8
48	42-7/16	40-3/8	59-7/8	72	2-3/4	44x1-1/2	56	71-1/8	86-3/4

# DIMENSIONAL DATA: 300# METAL SEATED BALL VALVE

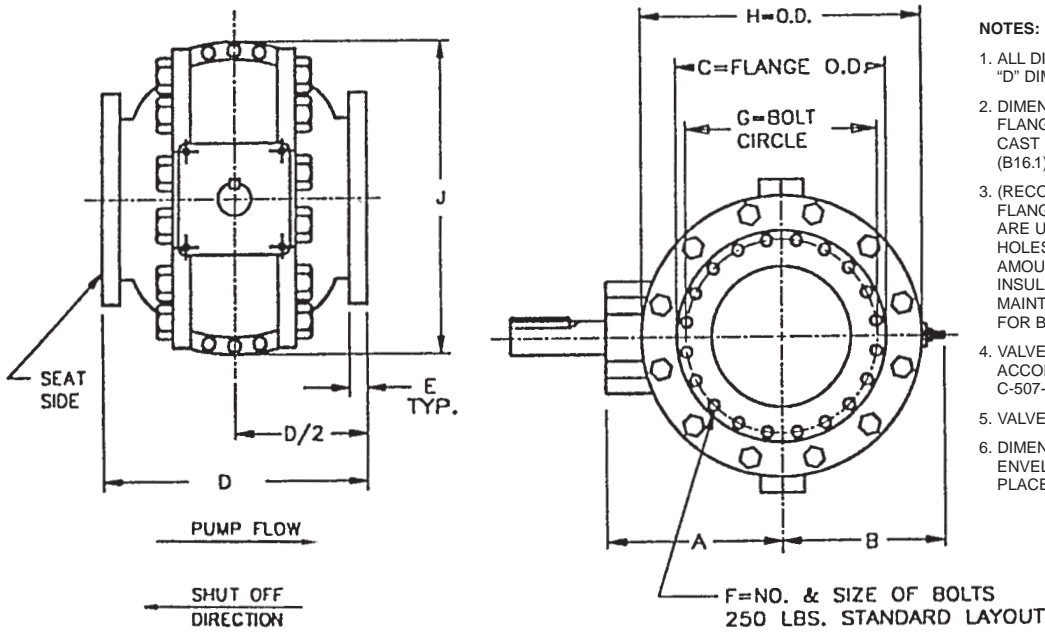

Valve Size	A	B	C	D	E	F	G	H	J
6	10	12	12-1/2	14-7/8	1-7/16	12x3/4	10-5/8	18	15-3/8
8	12-3/8	10	15-3/8	15-1/4	1-5/8	12x7/8	13	18-5/8	20-1/2
10	13-3/4	11-1/4	17-7/8	20-1/8	1-7/8	16x1	15-1/4	21-1/2	22
12	15-1/8	12-5/8	20-7/8	21-3/8	2	16x1-1/8	17-3/4	24-1/4	26-1/4
14	16-5/8	14-1/8	23-3/8	26-1/2	2-1/8	20x1-1/8	20-1/4	27-1/4	31-1/4
16	17-7/8	15-5/8	25-7/8	27	2-1/4	20x1-1/4	22-1/2	29-11/16	34-1/2
18	19-1/4	17-5/8	28-3/8	31	2-3/8	24x1-1/4	24-3/4	32-7/16	37-3/4
20	20-3/8	17-3/4	30-7/8	34	2-1/2	24x1-1/4	27	34-11/16	40-3/4
24	23-1/4	22	36-3/8	39-1/8	2-3/4	24x1-1/2	32	40-9/16	46-1/2
30	28-1/4	26-5/8	43-3/8	47-1/4	3	28x1-3/4	39-1/4	48-1/4	57-1/8
36	32-3/4	31-5/8	50-3/8	55	3-3/8	32x2	46	56-3/8	66-1/4
42	37-11/16	35-7/8	57-3/8	63	3-3/4	36x2	52-3/4	63-1/8	77-1/8
48	42-7/16	40-3/8	65-3/8	74-1/2	4	40x2	60-3/4	71-1/8	86-3/4

# 6"-48" 150# AND 300# METAL SEATED BALL VALVE WITH MDT AND CYLINDER ACTUATOR

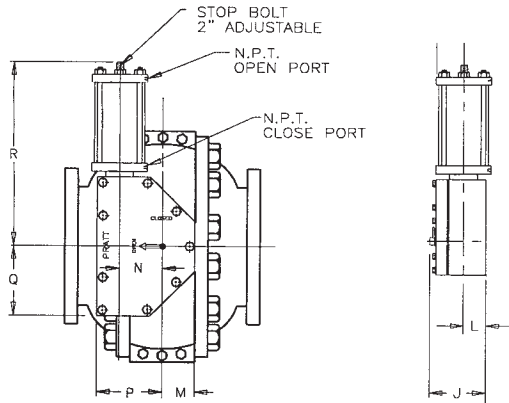

NOTES:  
1. ALL DIMENSIONS SHOWN IN INCHES.



MDT-15 with cylinder actuator

Actuator Size	J	L	M	N	P	Q	R
MDT-4S	8	4-1/2	3-3/8	4	7-5/16	6-3/4	27-3/8
MDT-5	10	5-5/8	4-1/2	5-1/2	8-3/4	10-1/2	33-1/2
MDT-6S	11	7-5/8	7	8-1/4	12-5/8	18-9/16	44-1/4
MDT-10	12-3/16	5-7/8	11-15/16	11-5/8	19-1/16	19-29/32	57-1/4
MDT-15	16-3/16	7-7/8	16-1/4	17-1/2	27-1/8	27-1/8	70-1/2

## DESIGN DETAILS: METAL SEATED BALL VALVE 150#

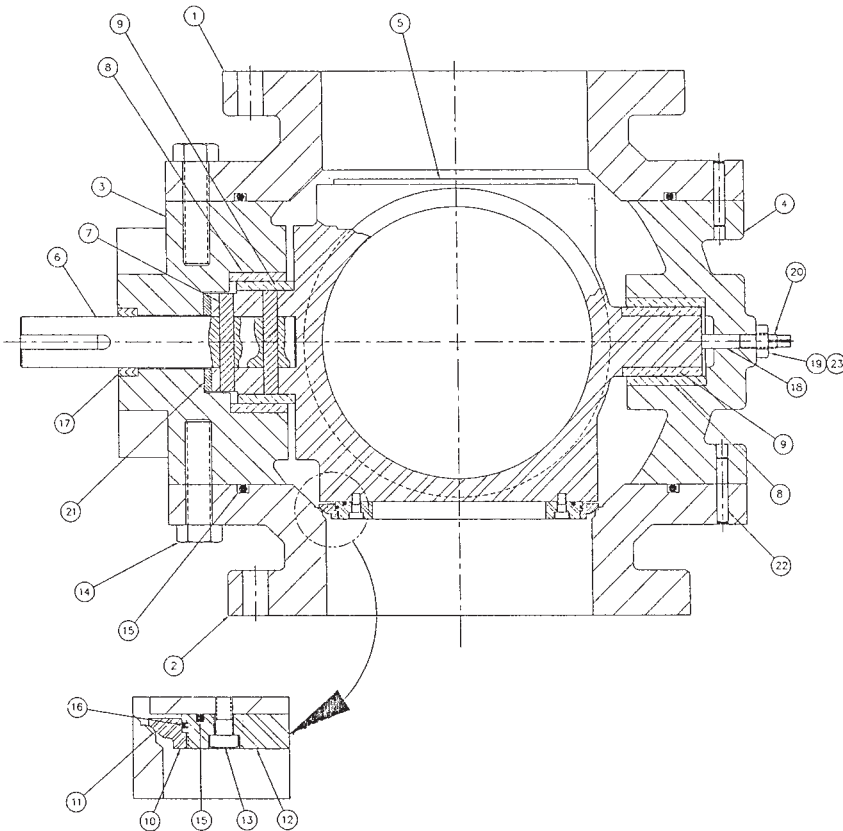

ITEM NO.	DESCRIPTION	MATERIAL
1	END PIECE (RIGHT)	DUCTILE IRON ASTM A536- GR:65-45-12
2	END PIECE (LEFT)	DUCTILE IRON ASTM A536- GR:65-45-12
3	CENTER PIECE (TOP)	DUCTILE IRON ASTM A536- GR:65-45-12
4	CENTER PIECE (BOTTOM)	DUCTILE IRON ASTM A536- GR:65-45-12
5	ROTOR	DUCTILE IRON ASTM A536- GR:65-45-12
6	SHAFTS	STN. STL. ASTM A564 TYPE 630 COND. H1150
7	SHAFT PINS	STN. STL. ASTM A564 TYPE 630 COND. H1150
8	BEARINGS (BODY)	BRONZE ASTM B271 GR. C95400
9	BEARINGS (ROTOR)	BRONZE ASTM B584 GR. C93200
10	SEAT (ROTOR)	STN. STL. ASTM A351 GRADE CF8M
11	SEAT (BODY)	MONEL ALLOY UNS: N04060
12	RETAINER RING	STN. STL. ASTM A240 TYPE 316
13	CAP SCREWS	STAINLESS STEEL ASTM A193 GRADE B8M ANSI TYPE 316
14	CAP SCREWS	CARBON STEEL SAE GRADE 8
15	O-RING	BUNA-N
16	O-RING	BUNA-N
17	V-TYPE PACKING	BUNA-N
18	THRUST BEARING	BRONZE ASTM B505 ALLOY C93200
19	SEALING NUT	CARBON STEEL ASTM A307 GRADE B
20	THREADED STUD	STN. STL. ASTM A564 TYPE 630 COND. H1150
21	THRUST COLLAR	BRONZE ASTM B584 GR. 93200
22	SPRING PIN	STAINLESS STEEL TYPE 420
23	PARKER "THRESEAL"	N/A

The full port ball valve with a properly selected automatic actuator is recognized by many experts in the industry as the ideal valve type for minimizing surges on pump start-up, shutdown and loss of power. In addition, the installed cost is often lower than other valve types and operating cost savings are lower than virtually all other valve types.

## LOWER INSTALLATION COST

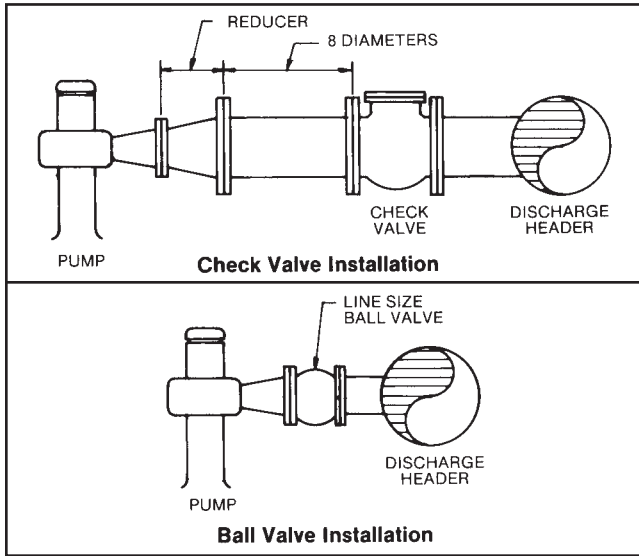

Center Post and Swing Check Valves have limitations based on maximum/minimum velocity and turbulence while efficient pump design has high exit velocities and considerable turbulence. The designer, therefore, must use an increaser on the pump discharge nozzle or specify a large discharge nozzle to accommodate the check valve. Additionally, some types of check valves require approximately 8 diameters of unrestricted pipe on the inlet side to ensure proper operation.

The Pratt Ball Valve does not have these restrictions and, therefore, the piping and building size can be smaller and less expensive.

## LOWER OPERATING COST

While center post, swing and globe-type check valves may cost less initially, their high operating cost in terms of energy usage continue for the life of the plant as the table below indicates.

Because of their full port area, ball valves minimize pumping costs. Annual power costs in dollars can be calculated.

$$\text{Cost} = \frac{QHRT}{(5810)(e)}$$

Q=Flow Rate, gpm  
 H=Head Loss, Feet of Water Column  
 R=Electric Rate, \$/KWHR  
 T=Yearly Use, Hours  
 e= Pump Efficiency

$$H=2.33 \left( \frac{Q}{Cv} \right)^2$$

Annual costs are summarized below for commonly used values based on 75% use, 8 feet per second flow, 12¢/KWHR and 80% efficiency.

Annual Operating Costs, Dollars						
Valve Size	Pratt Ball Valve	Butterfly Valve	Plug Valve	Globe Valve	Swing Check	Tilt Check
8	\$ 9.00	\$ 145.50	\$ 202.50	\$1077.00	\$ 210.00	\$ 127.50
12	19.50	213.00	457.50	2700.00	477.00	285.00
16	36.00	378.00	810.00	4350.00	855.00	510.00
24	79.50	574.50	1830.00	9300.00	1950.00	1140.00
30	124.50	900.00	2850.00	—	3000.00	1800.00
36	180.00	975.00	4125.00	—	4200.00	2550.00

Pratt Ball Valve Cv Full Open			
Valve Size	Cv	Valve Size	Cv
6	5250	24	84000
8	9330	30	131300
10	14600	36	189000
12	21000	42	257300
14	28600	48	336000
16	37300	54	425300
18	47300	60	525100
20	58300		

## TYPICAL PUMP/CHECK SURGE CONTROL SYSTEM

The Pratt Pump/Check Surge Control System employs a Pratt ball valve with appropriate actuator and controls to achieve tight shut-off in all applications. This is particularly desirable in waste water applications where tight shut-off is necessary to afford best possible working conditions downstream. This system is designed to minimize hydraulic shock within the piping system on both pump start and stop and is inherently reliable and maintenance free for long periods. The system consists of the ball valve with cylinder actuator and limit switches, and a hydraulic control panel. The control system may also include a pump start-pushbutton station.

Operating characteristics of the system include provision for adjustment of normal opening speeds from 60 to 300 seconds, and normal closing speeds from 60 to 300 seconds, and of emergency closure speeds from 10 to 30 seconds. This range of speeds normally provides adjust-

ment capable of eliminating excessive hydraulic shock in normal opening and closing modes.

The Pratt ball valve provides generally the same closure characteristics as other valve types used in pump check service, and *like all of these valves* its full stroke closing and opening time is the major factor in calculation of water hammer. Pratt suggests installation of surge relief protection in any system that has an emergency closure provision.

Operating with pressures from 40 to 150 psig, the Pratt system uses water, air or oil as an operating medium. While electronically powered solenoids control normal operation, the system is designed to automatically provide emergency closure with control circuit power failure. Manual override is possible at any time — with or without electrical power.

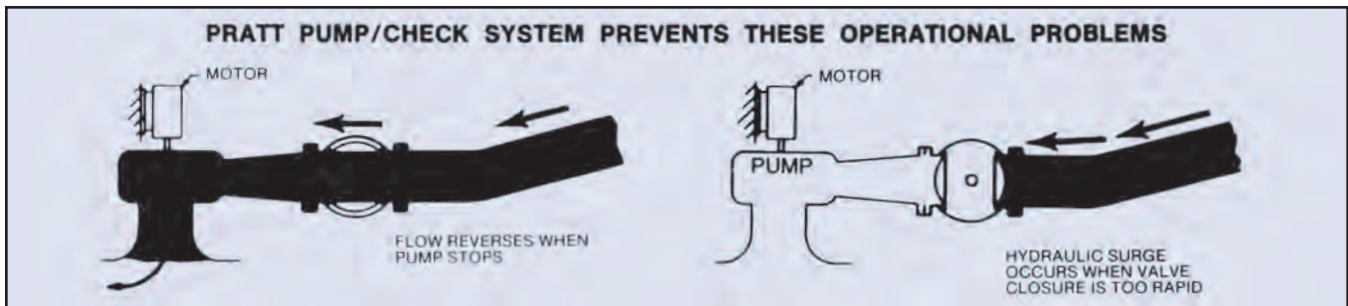

## DETAILS OF OPERATION

### Normal Pump Start

In this mode, the pump motor circuit is energized, thereby starting the pump. As the pump comes up to speed, or design head, three alternative methods are used to signal the Pratt pump/check valve.

**Single Pressure Switch** — The pressure switch is tapped off the upstream side of the pump/check valve. When the discharge pressure switch trips, it energizes the solenoid circuit to the four-way valve, causing the pump/check valve to open.

**Time Delay Relay** — The electrical device is part of the pump/motor circuit. Once the pump motor circuit is active the time delay relay is energized, which is preset to initiate the four-way valve circuit causing the Pratt pump/check valve to open. The amount of time delay is related to the type of pump and the time it takes for the pump to come up to speed.

**Differential Pressure Switch** — This pressure switch is tapped off the downstream and upstream sides of the Pratt pump/check valve. As soon as the pump/motor circuit is energized, the differential pressure switch is able to sense when the pump discharge pressure is greater than the downstream pressure, and trips the switch, closing the four-way valve circuit and causing the Pratt pump/check valve to open. During pump start, the two-way solenoid

valves are continuously energized and remain energized while the pump is on line.

### Normal Pump Stop

This mode of operation is selected when the pump is taken off line for reasons of demand, maintenance, etc. For normal close the four-way valve circuit is de-energized, causing the Pratt pump/check valve to close. (The two-way solenoid emergency bypass valves remain energized during normal pump stop.) While the Pratt pump/check valve moves toward the closed position the pump/motor set continues to run. The pump/motor circuit is tripped off by a limit switch on the Pratt pump/check ball valve. The point at which the limit switch trips out the pump/motor circuit relates to concerns of hydraulic surge in the system, pump speed, etc. However, for some installations the pump/motor circuit is tripped out prior to the Pratt pump/check valve reaching the full closed position. On some systems the Pratt pump/check valve is fully closed prior to tripping out the pump/motor circuit. The settings of the limit switch which trips out the pump/motor circuit are normally made in the field.

When the pump/motor circuit is tripped out, the two-way solenoid emergency bypass circuit can be de-energized.

# TYPICAL PUMP/CHECK SURGE CONTROL SYSTEM

## Emergency Closure

This mode of operation usually occurs when an electric power failure causes the pump/motor set to stop. In an incident of this nature the Pratt pump/check ball valve must close at a rate more rapid than normal closure rates. The need for rapid closure of the Pratt pump/check valve is to prevent a high reverse flow rate which can backspin the pump and cause damage to the pump/motor set and drain the system stored water.

On total electric power failure the four-way valve and the two-way bypass emergency valves are de-energized. The bypass piping circuit parallels the four-way valve circuit and provides a larger cylinder supply flow rate to the Pratt pump/check valve cylinder actuator resulting in rapid closure. If the pump/check ball valve has the feature of emergency closure, it is recommended that the pumping system piping should include surge relief devices.

## Typical Control Function

### Normal Pump Start

- Turn selector switch to "On" position.
- Press pump start button starting pump motor.
- When pump comes up to desired head, the pressure switch closes, energizing the four-way valve circuit, causing the Pratt pump/check valve to open.

### Normal Pump Stop

- Turn selector switch to "Off" position. This de-energizes four-way valve circuit causing the Pratt pump/check valve to close.
- When the Pratt pump/check valve reaches 75% to 95% close, the momentary limit switch trips, de-energizing the pump/motor circuit and shutting down the total system.

### Emergency Closure

All circuits are de-energized simultaneously allowing rapid closure through the two-way valve bypass piping.

On pump-check service, ball valve starts to open only after pump has reached desired speed (or pressure). When fully open, ball provides full circular waterway with no more pressure drop than an equivalent length of pipe. If power loss to pump occurs, valve closes at desired speed to prevent reversal of flow toward pump. Upon complete closure, valve is bubble-tight against back flow towards the pump.

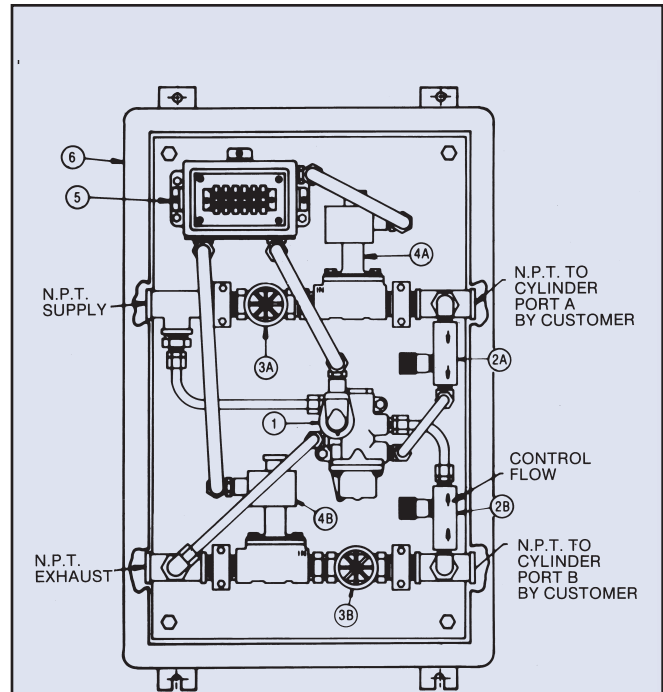

### Equipment Furnished

- |  |   |
|--|---|
| 1 — Two-Position Single Solenoid 4-Way Valve Manual Operator         | 4A & 4B — Single Solenoid 2-Way Valve (Normally Open) |
| 2A & 2B — Adjustable Flow Control (Normal Operations)                | 5 — NEMA Type IV Terminal Box with Terminal Block     |
| 3A & 3B — Balance and Stop Valve (Emergency Flow Control & Shut-Off) | 6 — NEMA Type XII Single Door Control Cabinet         |

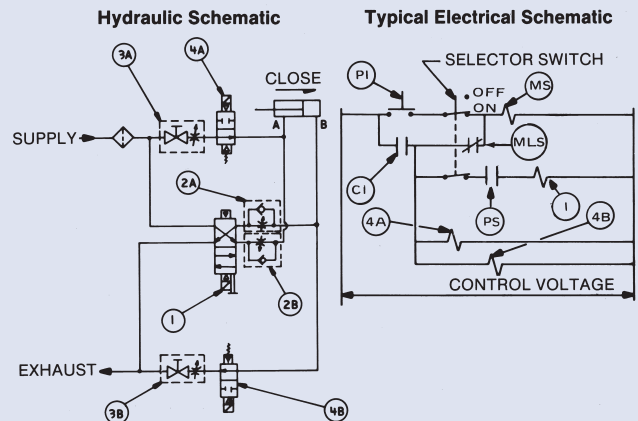

- C1 — Motor Starter Holding Contact
- P1 — Pump Start Button
- MS — Motor Starter Solenoid
- MLS — Momentary Limit Switch
- 1 — 4-Way Valve Solenoid Coils
- PS — Pressure Switch Contacts
- 4A, 4B — Emergency 2-Way Valve Solenoid Coils

## CONTROL APPLICATIONS

The ball valve has proven very effective in a wide variety of control valve applications — pressure reducing, pressure sustaining, system balancing, flow control, etc.

The basic structure of a full port ball valve has a flow path that extends its capabilities beyond that of a standard plug valve or butterfly valve. The ball in the throttled position has the effect of two plugs or discs to absorb the energy of the flowing media. Consequently, the ball valve's flow range and throttling capabilities are extended beyond that of a single plug or butterfly valve.

In addition, Pratt has standard control systems for most applications and a staff of experienced engineers to assist you in the design of custom applications.

In applications with severe throttling, cavitation can be a problem. Pratt has designed many systems to eliminate or minimize cavitation and has patented integral anti-cavitation devices that solve the majority of these problems.

## CHARACTERIZED CLOSURE

The chart below shows the relationship of ball valve ball angle to percent of full flow area. Also shown is similar data for a butterfly valve and plug valve. The ball valve has noticeably smaller slope approaching the closed position, producing a smaller change in unit flow per unit time at closure. This characteristic combined with characterization that may be available from the operator has a beneficial effect in reducing water hammer. **However, principal means of controlling water hammer remains in limiting speed of valve closure.**

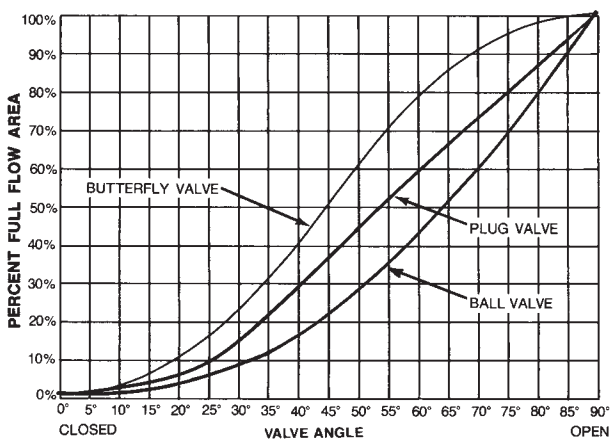

## SHUTOFF/BLOCK VALVE SERVICE

The ball valve is an excellent block valve. In the full open position, the pressure drop is the same as an equivalent length of pipe. In the closed position the Pratt metal seated ball valve meets the requirement for AWWA C507-(latest revision). Leakage past the closed seat shall not exceed 1 fluid ounce per hour per inch of nominal port diameter.

Because the Pratt ball valve is full ported and has high flow capabilities, many users combine it with a pair of reducers in a smaller than line size configuration. In these installations, the pressure loss is equivalent to the loss of a pair of reducers which in many cases is still less than the pressure loss through other types of line size valves.

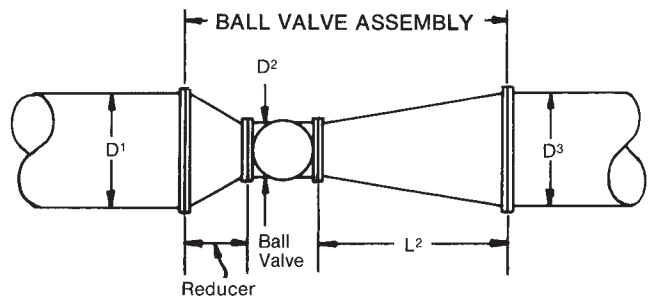

Computer generated head loss data can be provided.

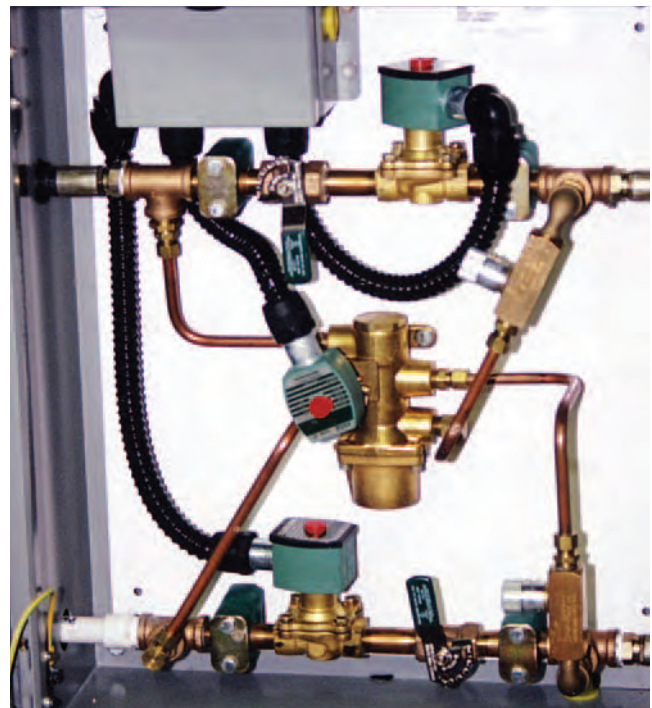

Pump check control system



# NOTES

## PRATT PRODUCT GUIDE

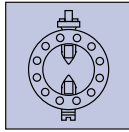

Model  
2FII

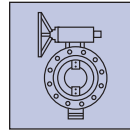

Triton®  
HP250

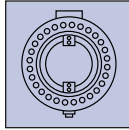

Triton®  
XR70

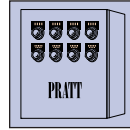

Control  
Systems

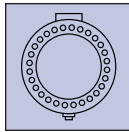

Triton®  
XL

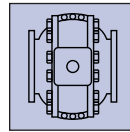

Metal Seated  
Ball Valve

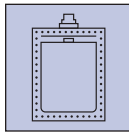

Rectangular

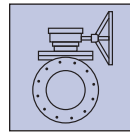

Plug  
Valve

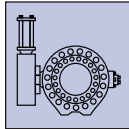

Rubber Seated  
Ball Valve

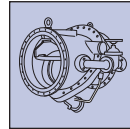

Tilting Disc  
Check Valve

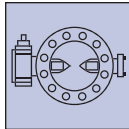

Groundhog®  
Valve

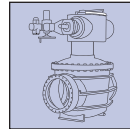

Cone Valve

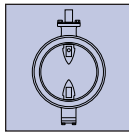

Monoflange  
MKII

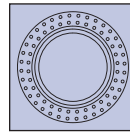

Sleeve Valve

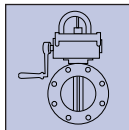

Indicating  
Butterfly Valve  
UL & FM approved

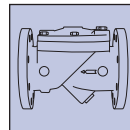

Check Valve

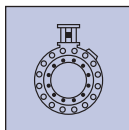

N-Stamp Nuclear  
Butterfly Valve

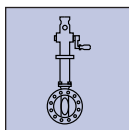

PIVA Post Indicating  
Valve Assembly  
UL & FM approved

# PRATT

### Henry Pratt Company

401 South Highland Avenue  
Aurora, Illinois 60506-5563

Toll Free 877-436-7977

630-844-4000

Fax 630-844-4160

[www.henrypratt.com](http://www.henrypratt.com)

ISO 9001: 2000 Certified