

# PRATT

Henry Pratt Company

*AWWA Rubber*

*Seated Ball Valve*



*Valves for the 21st Century*



## A Tradition of Excellence

With the development of the first rubber seated butterfly valve more than 70 years ago, the Henry Pratt Company became a trusted name in the flow control industry, setting the standard for product quality and customer service. Today Pratt provides the following range of superior products to the water, waste water and power generation industries.

**BUTTERFLY VALVES:** from 3" to 162"

**RECTANGULAR VALVES:** 1' x 1' to 14' x 16'

**BALL VALVES —**

**RUBBER SEATED:** from 4" to 60"

**METAL SEATED:** from 6" to 48"

**PLUG VALVES:** from 1/2" to 36", 3 ways

**HYDRAULIC CONTROL SYSTEMS**

**VALVE CONTROLS**

**ENERGY DISSIPATING VALVES  
AND FIXED ENERGY DISSIPATERS**

**CONE VALVES**

**CHECK VALVES**

## A Commitment to Meeting The Customers' Needs

Henry Pratt valves represent a long-term commitment to both the customer and to a tradition of product excellence. This commitment is evident in the number of innovations we have brought to the industries we serve. In fact, the Henry Pratt Company was the first to introduce many of the flow control products in use today, including the first rubber seated butterfly valve, one of the first nuclear N-Stamp valves, and the bonded seat butterfly valve.

## Innovative Products For Unique Applications

Though many of the standard valves we produce are used in water filtration and distribution applications, Pratt has built a reputation on the ability to develop specialized products that help customers to meet their individual operational challenges.

## Creative Engineering for Fluid Systems

Pratt's ability to provide practical solutions to complex issues is demonstrated by the following case histories.

### Earthquake Proof Valves

Pratt designed and manufactured hydraulically actuated valves for a water storage application so that the valves would automatically operate in the event of earthquakes. This led to the development of a valve that will withstand forces of up to 6g's.

### Custom Actuation/ Isolation Valves

Pratt designed and manufactured valves that would isolate a working chamber in the event of a nuclear emergency during the decommissioning of armed nuclear warheads. The valves were able to close in a millisecond using specially designed Pratt electro-pneumatic actuators.

### Valves Designed for Harsh Environments

Pratt designed and manufactured a 144" diameter butterfly valve for the emergency cooling system at a jet engine test facility. The valve was designed to supply water to help dissipate the tremendous heat generated by the engines during testing.

# PRATT

Henry Pratt Company

**Through experience, commitment and creative engineering, Pratt is uniquely suited to provide superior products for our customers' special needs. For more information, contact our corporate headquarters in Aurora, Illinois.**

## TABLE OF CONTENTS

SCOPE OF LINE .....	2
SUGGESTED SPECIFICATION.....	3
DESIGN DETAILS .....	4-5
FEATURES AND BENEFITS.....	6-7
APPLICATIONS .....	8
DIMENSIONS	
RUBBER SEATED BALL VALVE .....	9
MANUAL ACTUATORS .....	10
ELECTRIC ACTUATORS .....	11
TYPICAL COMMERCIAL MOTOR ACTUATOR .....	11
CYLINDER ACTUATORS.....	12
BALL VALVE INSTALLATION ADVANTAGES	
LOWER INSTALLATION COST .....	13
LOWER OPERATING COST.....	14
TYPICAL PUMP/CHECK SURGE CONTROL SYSTEMS .....	15
CONTROL APPLICATIONS .....	15-17

## SCOPE OF LINE: PRATT AWWA RUBBER SEAT BALL VALVES

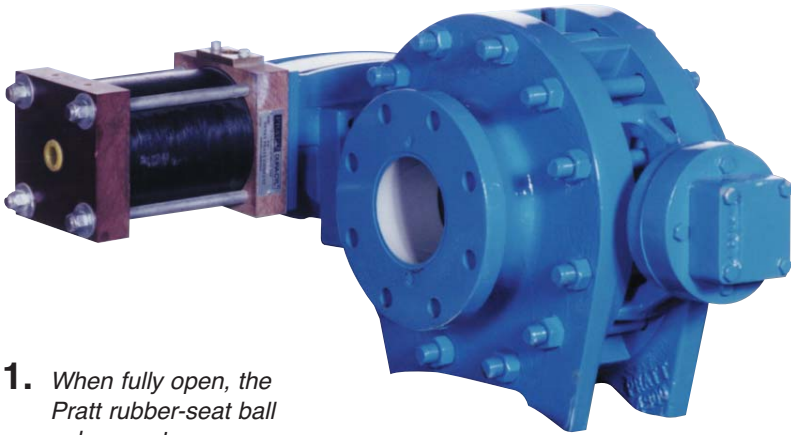

1. When fully open, the Pratt rubber-seat ball valve creates no more pressure drop than an equivalent length of straight pipe.
2. Ideal for throttling service with a streamline flow pattern.
3. When closed, the Pratt rubber-seated ball valve is bubble-tight.

### Sizes:

4" through 60"

### Body Style:

Flanged ends, three-piece cast construction single seat for unidirectional or double seat for bi-directional shutoff.

### Pressure Class:

AWWA C507 pressure classes 150 & 300 psi.

### Operators:

Manual: either Pratt MDT (traveling nut type) with nut, handwheel or chainwheel or worm gear operators; Cylinder operators for air, oil or water; Electric motor operators and a complete variety of accessories such as limit switches, control valves, positioner, push button controls, speed control devices and pressure switches.

### Controls:

Automatic pump/check; altitude tank regulation; check service, pressure regulating service.

### New Water and Waste Water Industry Standards:

For extended seat life, long-term drop tight closure, lower seating, unseating torque, lower maintenance, simplified operator controls.

The Pratt rubber-seat ball valve fully complies with AWWA standard C507 for tight-closing, shaft-mounted ball valves. It is a proven, rugged, through-port rotary valve that employs modern design techniques. The Pratt ball valve is suited to throttling and on-off service and is adaptable to a variety of control and shut off applications.

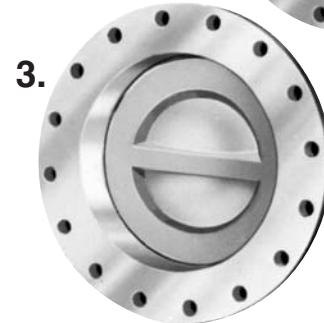
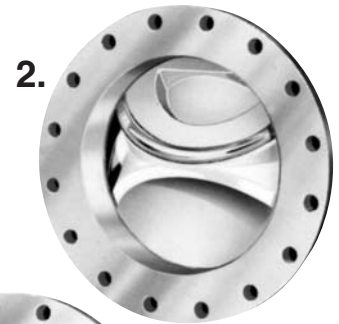

Pratt ball valve superiority begins with the use of a resilient seat and the E-LOK® seat retention system. Thus to the readily recognized advantages of a full-port unobstructed waterway and excellent throttling characteristics, Henry Pratt has added greatly extended seat life to the ball valve and at the same time has reduced operating forces and provided drop-tight closure. As a result, the ball valve becomes the ideal choice for a wide variety of applications where before only much heavier, more expensive and costly-to-maintain valve types were available.

In addition to over 100,000 successful E-LOK® seat installations since 1968, several tests at Pratt and independent laboratories have demonstrated the integrity of the E-LOK® seat design.

Pratt ball valves have been tested at 300 psi differential for 10,000 cycles per AWWA C-507, Section 5.2.4.3, proof-of-design requirements and tested bubble-tight at the conclusion of the cycle tests.

Ball valves have also been tested to prove their resistance to the effects of cavitation. After several free discharge cycles at 200 psi pressure, a test valve was subjected to a 100 hour continuous cavitation test at 95 psi differential pressure and a valve angle of 25 degrees. Line velocities in excess of 70 feet/second and localized velocities across the seat in excess of 100 feet/second were attained during the tests. At the conclusion of the tests, the valve was bubble-tight at 300 psi.

# SUGGESTED SPECIFICATIONS

## 1. General

All ball valves shall be of the tight-closing, shaft-mounted type that fully comply with AWWA Standard C507. Design pressure ratings shall be (150 psi) (300 psi) and provide tight shutoff against flow in (one direction) (both directions). Design of valve shall be such that with the valve in the open position, the full and unobstructed circular inlet and outlet port diameter shall be as specified in Table 1 of AWWA Standard C507. With the valve in the closed position, the rubber-seated valve shall be bubble tight at rated pressure.

## 2. Valve Body

The valve body shall have integral support legs or pads and shall consist of two body end pieces and a center body piece through-bolted and O-ring sealed against leakage. Minimum body thickness shall be as specified in Table 2 of AWWA Standard C507. Flanges shall be flat-faced and flange drilling shall be in accordance with ANSI B16.1 (Class 125) (Class 250).

## 3. Valve Ball and Shafts

The valve ball shall be constructed of ductile iron ASTM A536 65-45-12 or cast iron ASTM A48, Class 40, and shall be taper-pinned to an upper and lower fitted shaft of Type 304 or 17-4 Type 630 stainless steel. Valves employing chromium-plated iron or steel shafts or trunnions shall not be accepted.

## 4. Valve Bearings and Seals

The center section shall be fitted with sleeve-type bearings contained in the body hubs. Bearings shall be corrosion resistant and self-lubricating. Material shall be Teflon-lined with fiberglass backing. Bearing surfaces shall be isolated from flow by O-ring type seals. The ball assembly shall be supported by a two-way thrust bearing assembly consisting of a stainless steel stud and thrust collar in a grease-packed cavity.

## 5. Valve Seats – Rubber

All seats shall be of a synthetic rubber compound. Seats shall be retained in the valve body by mechanical means without retaining rings, segments, screws or hardware of any kind in the flow stream. Seats shall seal a full 360° without interruption and have a plurality of grooves mating with a spherical stainless steel seating surface on the ball. Valve seats shall be field adjustable around the full 360° circumference and replaceable without dismantling the operator, ball or shaft. Where line size permits, seats shall also be capable of being adjusted without removing the valve from the line. Manufacturer shall certify that the rubber seat is field adjustable and replaceable.

In single seated valves, there shall be one set of ball and body seats. In double-seated valves, there shall be two sets of ball and body seats. Single-seated valves shall provide drop-tight closure in one direction. Double-seated shall provide drop-tight closure in two directions.

## 6. Valve Actuators

Valve actuators shall conform to the operating requirements of AWWA Standard C507 and shall be designed to hold the valve in any intermediate position between full open and fully closed without creeping or fluttering.

- a. Manual actuators shall be of the traveling nut, self-locking type and shall be equipped with mechanical stop-limiting devices to prevent over-travel of the ball in the open or closed positions. Actuators shall be fully enclosed and designed to produce specified torque with a maximum pull of 80 lb. on handwheel or chainwheel and a maximum input of 150 ft.-lbs. on operating nuts. Actuator components shall withstand an input torque of 450 ft.-lbs. at extreme actuator positions without damage.
- b. Cylinder actuators shall move the valve to any position from full open to fully closed when a maximum of \_\_\_\_\_psi or a minimum of \_\_\_\_\_psi is applied to the cylinder. All wetted parts of the cylinder shall be corrosion resistant and cylinder rods shall be chromium-plated stainless steel. Cylinders furnished with enclosed operating mechanisms shall have all wetted parts constructed of non-metallic materials except the cylinder rod that shall be chromium-plated stainless steel. Rod seals shall be of the non-adjustable wear-compensating type. A rod wiper for removing deposits inside the cylinder shall be provided in addition to the external dirt wiper. Cylinder actuators of this type shall be Pratt MDT with Dura-Cyl cylinder.

## 7. Valve Testing

All ball valves shall be subjected to hydrostatic, shop leakage and performance tests as specified in Section 5.2 of AWWA Standard C507.

## 8. Valve Painting

All internal cast or ductile iron surfaces, except finished or bearing surfaces, shall be shop-painted with two coats of asphalt varnish conforming to Federal Specification TT-C-494.

All exterior steel or cast or ductile iron surfaces of each valve, except finished or bearing surfaces, shall be shop painted with one or more coats of Alkyd primer. For buried service valves, two coats of asphalt varnish per Federal Specification TT-C-494.

## 9. Proof of Design

The manufacturer furnishing valves under the specification shall be prepared to show that the valves proposed meet the proof of design requirements of AWWA Standard C507, Section 5.3.

# DESIGN DETAILS

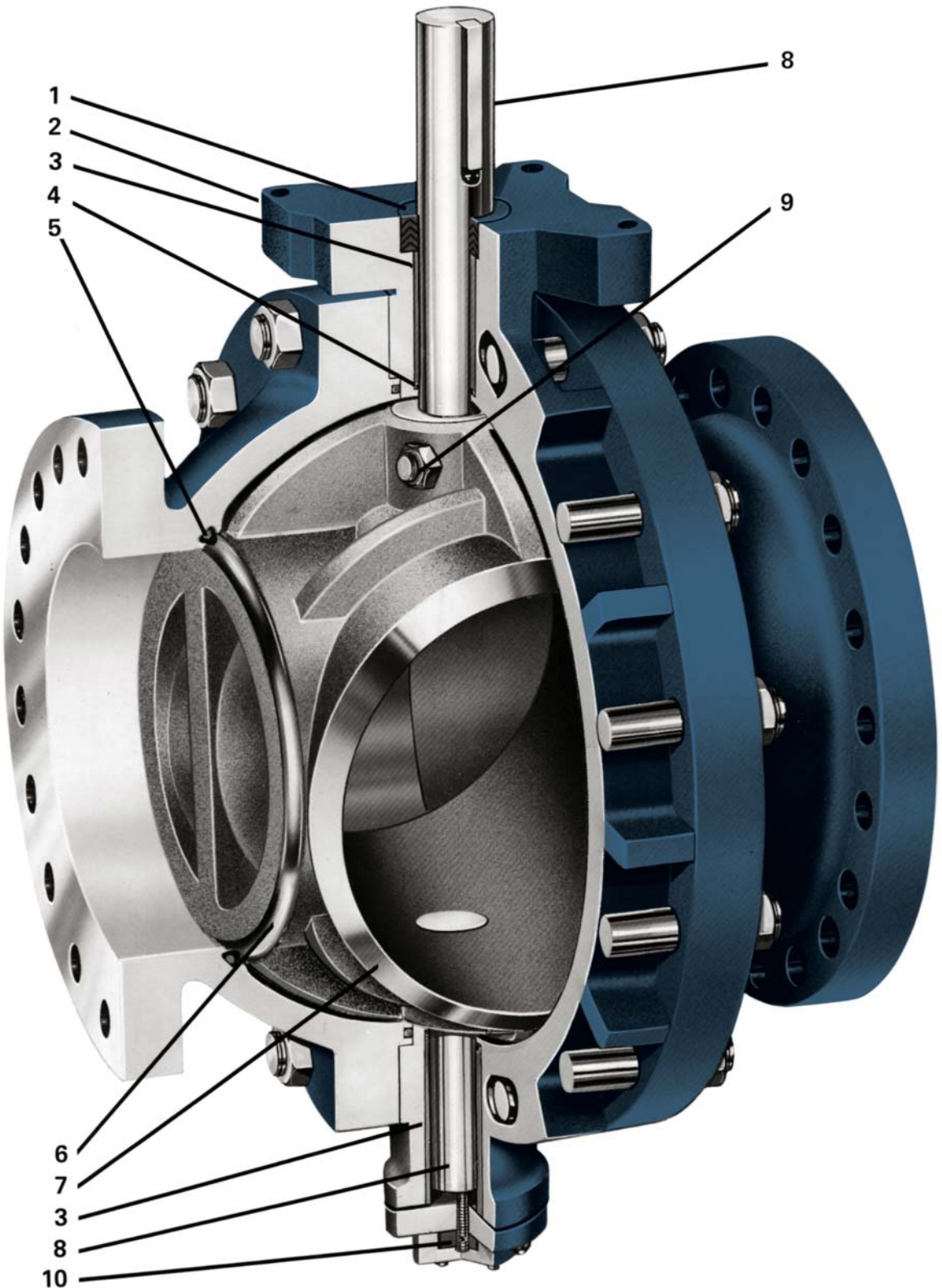

# VALVE DATA

## 1. Packing

Packing is self-adjusting “V” type located in trunnion of valve body where the shaft protrudes for operator connection. It is readily accessible without having to dismantle the valve.

## 2. Body

The valve body has integral support legs or pads and consists of two end pieces and a center body piece through-bolted and O-ring-sealed against leakage. The center body casting houses the bearings. Minimum body shell thickness is in strict accordance with AWWA C507 and flanges are drilled in accordance with ANSI B 16.1 for either Class 125 or Class 250 flanges.

## 3. Shaft Bearings

Self-lubricating sleeve-type bearings are used in both trunnions of the valve body. Bearings support the shaft and provide minimum friction during shaft rotation. Bearing load does not exceed 2000 psi. Bearing material is Teflon-lined with special non-metallic backing. This type of bearing offers electrical insulation qualities between ball/shaft assembly and the valve body, thereby eliminating concern for effects of galvanic corrosion. In addition, its reduced coefficient of friction requires far less operating torque than bearing materials used in the past.

## 4. Bearing Seal

An O-ring bearing seal prevents foreign material from scoring bearings. Extra long bearing life is assured.

## 5. Rubber Seat

Seat has multi-ridge surface of specially compounded rubber that seals a full 360° against a stainless steel or nickel-chrome spherical surface on the ball. Because of the laterally spaced grooves, rubber stress is reduced substantially, resulting in less sealing torque and longer seat life. It is mechanically retained by a specially formulated epoxy compound that keeps the seat in uniform contact pressure with the seating surface on the ball when in the closed position. This insures drop-tight sealing. The seat is replaceable in the field.

## 6. Seating Surface

Quarter-turn ball has corrosion-resistant stainless steel or nickel-chrome spherical seating surface mating with the rubber seat in the body end-piece. One or two sets of seats can be provided depending on shut-off requirements.

## 7. Ball

Spherically shaped ball features full line-size circular waterway in one direction, and at 90° position, provides drop-tight sealing. Absolutely no obstructions in the waterway to cause additional pressure drop.

## 8. Shafts

The shafts are turned and ground ASTM A-276 type 304 stainless steel generously sized to meet the most adverse conditions of flow and pressure.

## 9. Taper Pins

Large stainless steel 18-8 type 304 taper pins – threaded at one end and secured with lock washers and nuts – are used to attach shaft to the ball. Fit is such that shaft and ball are, in effect, one piece – with no looseness or vibration possible.

## 10. Thrust Bearing Assembly

Two-way thrust bearing is preset at the factory and consists of a stainless steel stud fastened to the bottom of the valve shaft. Stud extends beyond the bottom cover. The thrust collar is threaded to the stud and pinned. Bottom cover cap is then bolted to the bottom cover and retains the thrust collar, which in turn retains position of the assembly. The cavity that contains the thrust collar is packed with grease providing lifetime lubrication of thrust bearing assembly. Cap is fully gasketed to prevent leakage.

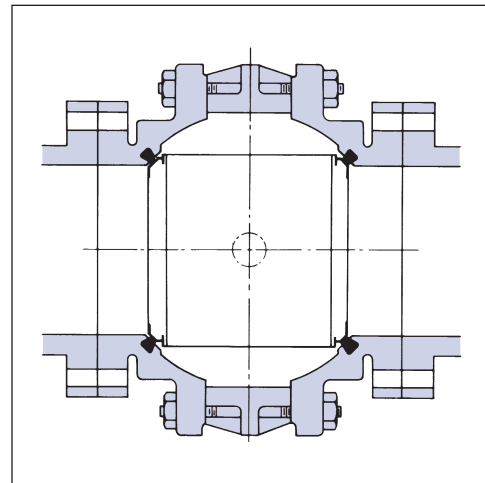

*The cross-section drawing (above) illustrates the closed position utilizing dual seats. This arrangement is furnished when flow from either direction in the pipeline requires tight shut-off.*

*In those cases where flow in only one direction is encountered, a single rubber seat ring would be furnished and the valve would be installed so that the seat would be downstream from the pressure source.*

# FEATURES AND BENEFITS

## Pratt Ball Valves

Henry Pratt introduced the rubber seated ball valve over 30 years ago and this Pratt design has been refined over the years. In addition to replacing most other full port valves, the Pratt ball valve is used extensively in applications where swing check and globe-type check valves were formerly used.

The Pratt ball valve has also found extensive applications in high velocity service such as hydroelectric and gravity feed lines where line velocities exceed 50 feet per second. In high-pressure shutoff applications, localized velocities across the seat routinely exceed 100 feet per second. The Pratt ball valve is equally effective as a long lasting shutoff device in potable, raw water and raw sewage applications.

**Full Port** Pratt ball valves offer the following features and benefits to the user:

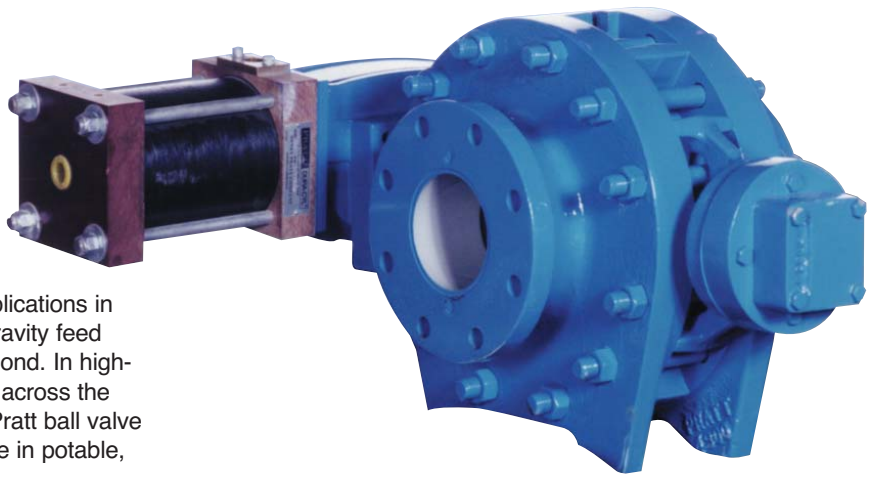

<u>Feature</u>	<u>Benefit</u>
Low Head Loss	<ul style="list-style-type: none"> <li>• Lower pumping cost</li> <li>• Smaller line sizes</li> <li>• Operates equally well at high or low velocities</li> <li>• Smaller pump nozzles and discharge lines</li> </ul>
Unaffected by Line Turbulence	<ul style="list-style-type: none"> <li>• Suitable for free discharge applications</li> <li>• Mount directly on pump nozzle</li> <li>• Mount directly on elbows</li> <li>• No restrictions regarding installation</li> </ul>

<u>Feature</u>	<u>Benefit</u>
Non-Clogging	<ul style="list-style-type: none"> <li>• Can handle sludge, raw sewage and raw water as well as potable water</li> <li>• Can be pigged</li> </ul>

In addition to a full port, the Pratt ball valve offers other major features and benefits to the user.

Pratt E-LOK	<ul style="list-style-type: none"> <li>• Seals drop tight at all pressures from zero psi to valve rating</li> </ul>
Rubber Seat	<ul style="list-style-type: none"> <li>• Shutoff not dependent upon line pressure</li> <li>• No hardware to corrode or work loose</li> <li>• Easily field repairable</li> </ul>
Non-Metallic Bearings	<ul style="list-style-type: none"> <li>• Corrosion resistant</li> <li>• Die-electric material significantly reduces potential for galvanic corrosion</li> </ul>
300 Series Stainless Steel Shaft	<ul style="list-style-type: none"> <li>• Protection against potential shaft corrosion</li> </ul>
Chevron Packing	<ul style="list-style-type: none"> <li>• Wear compensating, self-adjusting – No adjustment or replacement necessary</li> </ul>



*Ball valve in distribution pump station.*

# ONLY THE PRATT RUBBER SEAT BALL VALVE OFFERS THESE FEATURES

## E-LOK® Seating Principle

Pratt ball valves incorporate the innovative E-LOK® seat-retention system. The rubber seat, which is mounted in the body of the valve, seals a full 360 degrees against a corrosion resistant surface on the ball. The E-LOK® seat design lowers stress and eliminates permanent compression set because of the ridges and grooves molded into the seat surface. In assembly, a specially compounded epoxy is injected into a channel behind the rubber seat with the ball in the closed position. As the epoxy is injected the seat is moved against the ball seat surface with uniform ball-seat interference around the entire periphery. The epoxy compound then hardens without bonding to the metal surfaces in the seat groove or rubber seat. The result is the E-LOK® seat retention system – a standard in drop-tight closure without seat retention hardware that is tamper-prone or can loosen/corrode and potentially damage pumps or other expensive auxiliary equipment. If seat replacement should ever be required, it can be performed in the field. The factory-installed rubber seat can be removed from the valve with ordinary hand tools. A replacement can be installed and the original drop-tight seal restored by utilizing a seal kit available from Pratt.

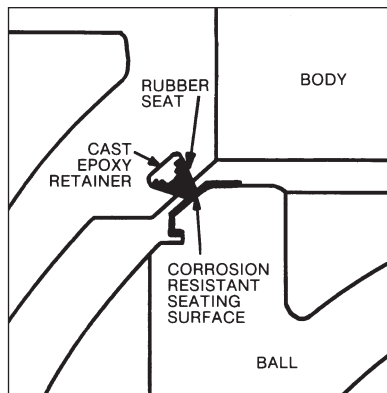

*The E-LOK® seat design can assure longer seat life and better sealing action. By mounting the rubber seat in the body rather than on the ball the rubber seat is less likely to be damaged by debris in the flow stream where the valve is used in waste water applications.*

## Body Design Eliminates Distortion

Heavy pipe loads will have no adverse effects on the Pratt ball valve. The three-piece body design transmits pipe loads from one end section to the other by means of the through-bolts. This reduces stress on the all important middle section, which maintains shaft-ball-seat alignment within very close tolerances.

## Resilient Rubber Seat

Only with a Pratt resilient seat is it possible to:

1. Eliminate wedging, binding and excessive wear associated with metal-to-metal seating valves.
2. Eliminate the effects of line distortion. Body stresses (caused by line settling or uneven bolting) will not cause seat binding. Valve will remain tight and easy to operate through thousands of cycles.
3. Provide drop-tight sealing against all pressures from zero to 300 psi.
4. Substantially lower seating/unseating torque requirements.

5. Adjust or replace seat in the field to full factory specifications.
6. Use the ball valve with confidence for a wide variety of applications including pump/check, throttling, altitude, pressure regulating, high-pressure transmission and check service.

## Does Not Require Exercising

Operates smoothly and easily even if it has been in one position for long periods.

## Fully Protected Seat

By mounting the rubber seat in the body, Pratt engineers have lessened the possibility of solids damaging the seating surfaces where the valves are used in waste water applications.

## Non-Clogging Design

The Pratt ball valve is designed to give a self-cleaning flow pattern through the ball and body. This is particularly desirable on certain sludge and waste water applications.

## Permanently Lubricated Bearings

Bearing material is Teflon lined, with special high strength non-metallic backing that provides a permanent low coefficient of friction and controlled shaft support. These electrically non-conductive, conservatively sized sleeve-type bearings are the latest bearing material development for long trouble-free operation. No shaft-to-bearing galvanic reaction resulting in corrosion is possible.

## Completely Interchangeable Parts

The Pratt ball valve is not custom produced. The user benefits from the economy of modern production methods and perfectly fitted, completely interchangeable parts.

## Low Head Loss

When fully open, the Pratt ball valve creates no more head loss than an equivalent length of straight pipe. Frequently allows the use of "smaller than line size" valves as a cost advantage over line size valves with obstructed waterways.

## Less Weight – Smaller Dimensions

Unique Pratt design enables savings in weight and overall dimensions without sacrificing traditional Pratt ruggedness.

## Single or Double Seat Design

Furnished with two seats to shut off flow in either direction or one seat for unidirectional shut off.

## Less Complex, More Reliable

The Pratt ball valve operators are totally enclosed and feature a simplified operating mechanism. They are suitable for buried service without the use of expensive vaults. Manual operators, which completely conform to AWWA Standard C507, are furnished with handwheels, chainwheels or AWWA nut and operate so easily that one person can open or close the ball valve against full line pressure. Automatic operators are electric motor or cylinder (air, oil or water). When required, it is possible to furnish a locking device that holds the valve shaft in position so that the operator may be removed for inspection or repair while the valve is still on line.

# APPLICATIONS

## Altitude Tank Regulation

The Pratt "Level-Trol" System is designed to maintain automatically a proper water level in storage tanks. It will sense system pressure changes as low as 0.5 psi and may be set to regulate level at any point from 15 to 75 psig.

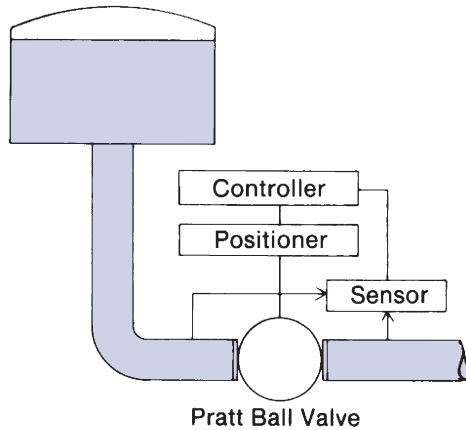

The non-electric system includes a pilot pressure operated three-way valve and a four-way valve and ball valve operating cylinder. Closing speed is adjustable. A dual supply pressure source with filter and check valves assures proper operating pressure for the control system. An electrical "Level-Trol" system that uses pressure switches as sensors will activate the valve with either a motor or water cylinder actuator.

## Pressure Regulating Service

The Pratt rubber-seat ball valve is ideally suited to throttling service with its simple 90° angular movement that can be smoothly accomplished with a variety of positioners.

Pressure may be sensed with an electric or pneumatic transmitter that feeds the appropriate controller. Controller output may operate the Pratt Positioner that utilizes water pressure as the operating medium.

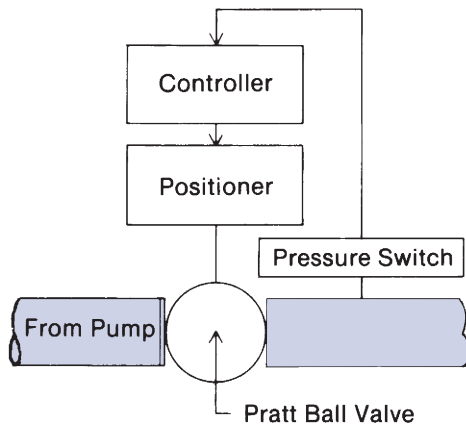

An advantage to the Pratt valve is its self-cleaning action from flow through the body as well as the ball.

## Line Service

Where water lines or sewage force mains require sectionalizing valves, the Pratt ball valve is ideal. Operating is always easy and shut-off is always complete

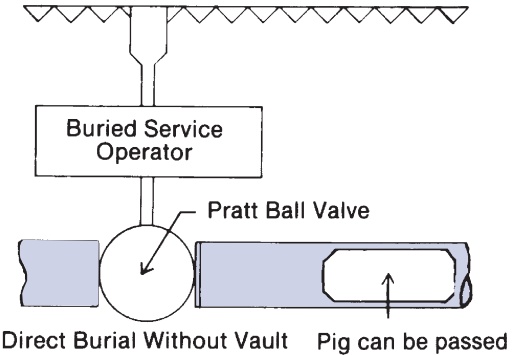

because the only contact between the body and ball is the rubber seat. The valve can remain in one position for years and still provide quick, reliable action when required. In underground lines, the valve may be directly buried without expensive concrete vaults.

## Surge Control Options

Pratt recognizes the fact that each application involving the pumping of fluids is unique. For this reason we have developed a variety of standard control systems to accommodate most system design requirements. Control systems are available to operate on various types of supply media. Accumulator systems or compressors can be provided if an existing supply media is not available.

In addition to the typical pump/check surge control system detailed on following pages, systems can be provided to incorporate pressure reducing, back pressure sustaining, flow control and level control features.

Pratt also offers a variety of standard electrical control panels to provide the interface between the pump control cabinet and the above described hydraulic or pneumatic surge control systems. These electrical control panels control the pump and the pump discharge valve. In addition, they are designed to indicate valve position, monitor system conditions, provide alarm signals and shut the valve during undesired conditions.

For detailed information concerning Pratt control systems, contact your local Pratt representative.

## VALVE DIMENSIONS

The dimensions shown are for valve without actuator and accessories. Add appropriate actuator and accessory dimensions to valve dimensions for overall size. When determining overall size of a system using a hydraulic cylinder note that a much smaller overall size is available by using the Pratt self-contained oil hydraulic system, for which cylinder dimensions may be obtained from the factory. All dimensions shown in inches.

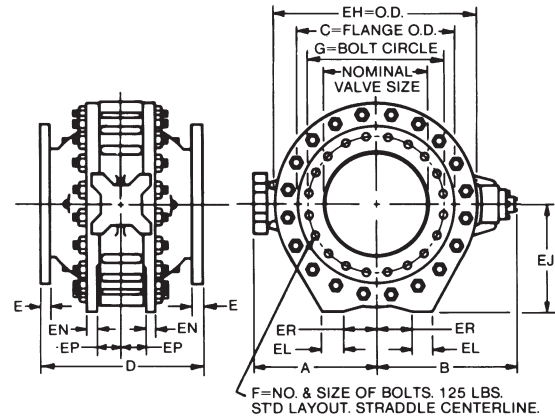

## 150 PSI BALL VALVE DIMENSIONS

VALVE SIZE	A	B	C	D	E	F	G	EH	EJ	EL	EN	EP	ER
4	9-7/8	12-5/8	9	12-3/8	15/16	8-5/8	7-1/2	14-3/8	8-1/8	1-7/8	1-3/4	1-3/8	3-3/8
6	10-1/2	13-3/16	11	16	1	8-3/4	9-1/2	16-1/2	9	2-5/16	1-15/16	1-5/16	2-15/16
8	11-1/8	13-15/16	13-1/2	18	1-1/8	8-3/4	11-3/4	19	10-1/8	2-1/4	1-3/8	2-1/8	4-1/4
10	12-7/8	16-1/8	16	18-1/8	1-3/16	12-7/8	14-1/4	22	11-7/8	2-7/8	1	2-1/2	4-9/16
12	15	18-1/2	19	21	1-1/4	12-7/8	17	25-3/4	13-1/2	3-1/2	1-1/8	2-1/2	4-5/16
14	17-3/8	20-5/8	21	26-1/4	1-3/8	12-1	18-3/4	29-3/4	15-1/2	3-15/16	1-5/16	2-1/2	4-15/16
16	20-1/16	23-1/4	23-1/2	27	1-7/16	16-1	21-1/4	32-7/8	17	4-3/16	1-7/16	2-9/16	5-7/16
18	21-9/16	24-7/8	25	29	1-9/16	16-1 1/8	22-3/4	36-5/8	19	4-5/16	1-9/16	3-3/16	6
20	23-5/8	27-3/4	27-1/2	32	1-11/16	20-1 1/8	25	39-7/8	20-3/4	4	1-5/8	4-7/16	6-11/16
24	26-1/2	29-3/4	32	37	1-7/8	20-1 1/4	29-1/2	44-3/4	24-1/8	4-3/8	1-15/16	5-3/16	8-3/16
30	32-1/2	35-7/16	38-3/4	46	2-1/8	28-1 1/4	36	55-5/8	29-3/4	5-3/8	2-3/8	6	10-7/8
36	36-7/8	41-1/16	46	54	2-3/8	32-1 1/2	42-3/4	65-3/8	34-3/4	5-13/16	2-7/8	7	9-3/16
42	42-1/2	47-1/4	53	59-1/2	2-5/8	36-1 1/2	49-1/2	75-1/2	39-3/4	7-1/2	2-7/16	8	13-1/2
48	50-3/8	58-1/16	59-1/2	72	2-3/4	44-1 1/2	56	86-3/4	43-5/8	7	3-5/8	9-1/4	13-1/4

## 300 PSI BALL VALVE DIMENSIONS

VALVE SIZE	A	B	C	D*	E	F	G	EH	EJ	EL	EN	EP	ER
4	9-7/8	12-5/8	10	13	1-1/4	8-3/4	7-7/8	14-1/4	8-1/8	1-7/8	1-3/4	1-3/8	3-3/8
6	10-1/2	13-3/16	12-1/2	16	1-7/16	12-3/4	10-5/8	16-1/2	9	2-5/16	1-15/16	1-5/16	2-15/16
8	11-7/8	13-15/16	15	18	1-5/8	12-7/8	13	19	10-1/8	2-1/4	1-7/8	2-1/8	4-1/4
10	12-7/8	16-1/8	17-1/2	20-1/8	1-7/8	16-1	15-1/4	22	11-7/8	2-7/8	1-11/16	2-1/2	4-9/16
12	15	18-1/2	20-1/2	24	2	16-1 1/8	17-3/4	25-5/8	13-1/2	3-1/2	1-7/8	2-1/2	4
14	17-3/8	20-5/8	23	27-3/4	2-1/8	20-1 1/8	20-1/4	29-3/4	15-1/2	3-15/16	2-1/16	2-1/2	4-15/16
16	20-1/16	23-1/4	25-1/2	28-1/8	2-1/4	20-1 1/4	22-1/2	33	17-1/8	4-3/16	2-1/4	2-9/16	5-7/16
18	21-9/16	24-7/8	28	31	2-3/8	24-1 1/4	24-3/4	36-5/8	19	4-5/16	2-3/4	3-3/16	6
20	23-5/8	27-3/4	30-1/2	34	2-1/2	24-1 1/4	27	39-7/8	20-3/4	4	2-3/8	4-7/16	6-11/16
24	28	31-1/8	36	42-3/4	2-3/4	24-1 1/2	32	46	24-1/8	4-3/8	2-3/4	5-3/16	8-3/4
30	34-5/8	38-5/16	43	50-1/4	3	28-1 3/4	39-1/4	57-1/4	29-3/4	5-3/8	3-5/16	6	10-7/8
36	40-3/4	44-5/8	50	54	3-3/8	32-2	46	67-1/4	34-3/4	5-13/16	3-7/8	7	9-3/16

\* D +- 1/16" thru 10" Valves. +- 1/8" for 12" Larger Valves. F = No. + Size of Bolts

# MANUAL ACTUATORS

Pratt MDT manual actuators in the sizes used for operation of ball valves are the compound lever traveling nut type. They provide characterized closure, which by slowing down valve travel as the valve approaches the closed position, minimizes the possibility of line shock. The high input torque capacity – 450-foot pound maximum and a 200-pound pull on handwheel or chainwheel – provides inherent protection from operator misuse.

The Pratt MDT actuator is self-locking without a unidirectional sustained force from the valve. It can be relied upon to maintain exact valve position under conditions of fluctuating, turbulent and intermittent flow, yet one person can smoothly and easily operate the valve against full line pressure.

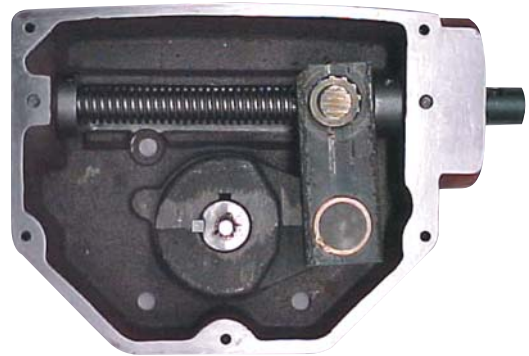

## DIMENSIONS

OPERATOR SIZE	J	L	M	N	P	Q	R	S	T	V	W
MDT-3S	7-1/4	4-1/16	3-1/4	3-5/32	5-5/8	5-7/16	10-3/16	10-1/2	10	12	9-1/8
MDT-4S	8	4-1/2	3-3/8	4	7-5/16	6-3/4	11-5/16	11-1/2	11	12	9-1/8
MDT-5	10	5-5/8	4-1/2	5-1/2	8-3/4	10-5/8	17	17-1/8	17-7/8	18	16-7/16
MDT-5S	10-3/4	6-1/8	5-5/8	7	10-5/8	16	19-7/8	20	20-3/4	24	22-1/4
MDT-6S	12-7/8	7-5/8	7	8-1/4	12-5/8	18-5/8	25-7/8	26-3/4	25-7/8	24	22-1/4
MDT-10	12-3/16	5-7/8	11-15/16	11-5/8	19-1/16	19-29/32	28-1/4	—	—	—	—
MDT-15	15-3/8	7-7/8	16-1/4	17-1/2	27-1/8	27	40	—	—	—	—

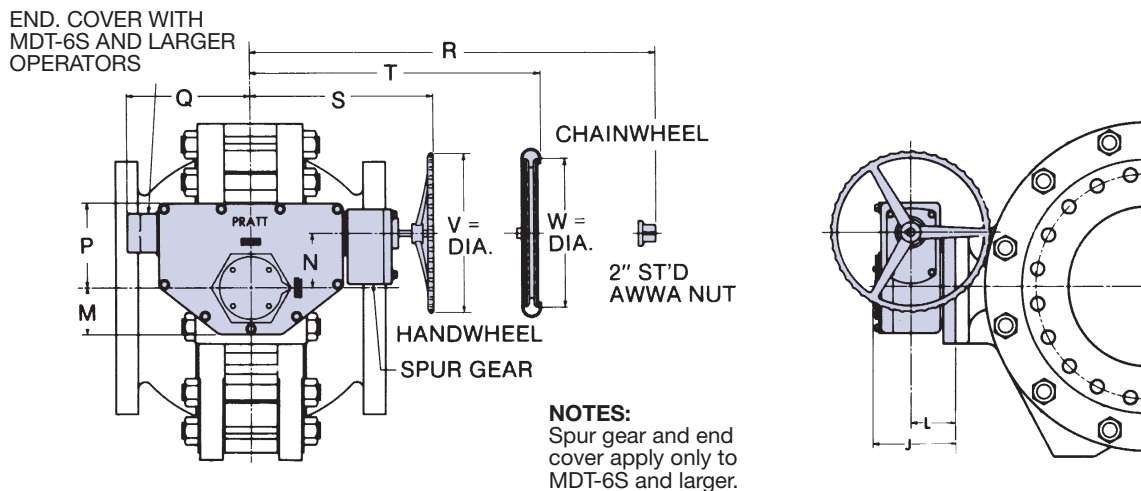

## ELECTRIC ACTUATORS

For 16 inch or smaller ball valves Pratt recommends the Pratt Positron with the Pratt MDT gear box as the ideal combination for most applications. Pratt also offers a variety of motor-gear reducer combinations from a variety of vendors. Regardless of choice, every operator has a high torque motor specifically

designed for valve control service, limit switches and provisions for manual operation. The standard housing is weatherproof. Various controls and accessories can be provided to meet specific user requirements.

## PRATT POSITRON/MDT MOTOR ACTUATOR

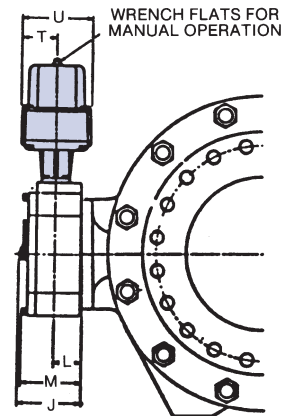
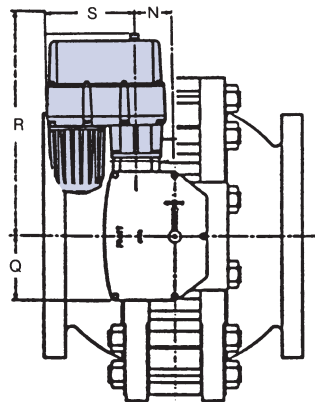

OPERATOR SIZE	J	K	L	M	N	P
MDT-2S	4-11/16	4-3/8	2	2-1/8	2	4-1/2
MDT-3S	5-5/8	5-1/8	2-7/16	3-1/4	3-3/32	5-5/8
MDT-4S	6-3/8	6	2-7/8	3-7/8	4	7-5/16

OPERATOR SIZE	G	R	S	T	U	V
MDT-2S	4-1/4	15-5/8	7-3/4	3-1/8	6-1/4	3/4
MDT-3S	5-3/8	17-9/16	7-3/4	3-1/8	6-1/4	3/4
MDT-4S	6-3/4	18-7/8	7-3/4	3-1/8	6-1/4	3/4

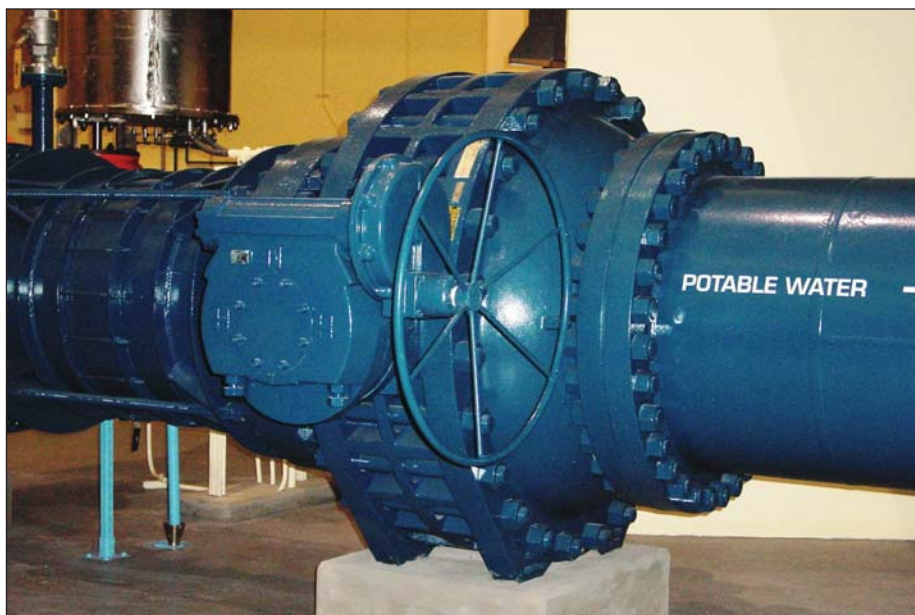

36" Rubber Seated Isolation Valve Application.

# CYLINDER ACTUATORS

Cylinder actuated MDT actuators are available for most applications.

The unique Pratt Dura-Cyl® non-metallic cylinder makes water cylinder operation more reliable than ever before possible with metallic cylinders. The cylinder design features high resistance to impact and eliminates the galvanic corrosion of piston, cap and head ends induced by the proximity of bronze to ferrous metals in a conductive solution.

The flexural strength, modulus of elasticity, water absorption and friction coefficients of the materials used in Dura-Cyl® cylinders are ideally suited for long life in water service. Suitable for use with air, oil, water or air/oil combinations up to 150 psi.

A manual override handjack accessory (not shown) is available whenever it is desirable to operate the valve manually in case of operator supply pressure failure. Cylinder accessories such as solenoid valves, limit switches, speed controls and positioners are available as standard.



Rubber Seated Ball Valve

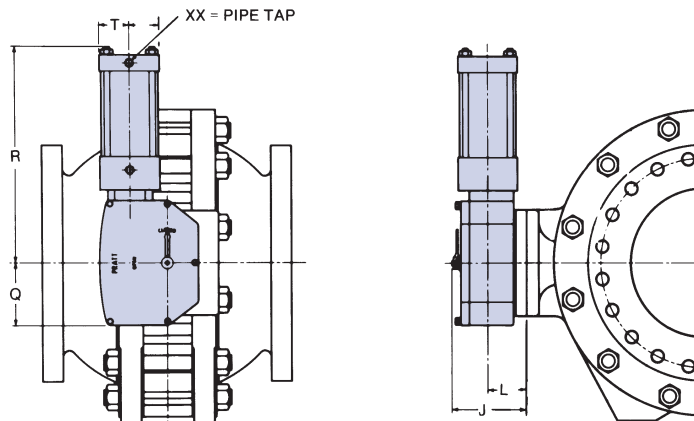

OPERATOR SIZE	CYLINDER BORE	STROKE SIZE	J	L	Q	R	T	XX
MDT-3	5	5-5/8	7-1/4	4-1/16	5-7/16	17-3/4	2-7/8	-1/2
MDT-3	8	5-5/8	7-1/4	4-1/16	5-7/16	18-5/16	4-3/8	-3/4
MDT-3	10	5-5/8	7-1/4	4-1/16	5-7/16	19-1/4	5-3/8	-3/4
MDT-4	5	8	8	4-1/2	6-3/4	21	2-7/8	-1/2
MDT-4	8	8	8	4-1/2	6-3/4	21-3/4	4-3/8	-3/4
MDT-4	10	8	8	4-1/2	6-3/4	22-3/4	5-3/8	-3/4
MDT-4	12	8	8	4-1/2	6-3/4	27-1/8	6-3/8	1
MDT-5	6	11	10	5-5/8	10-5/8	27-1/4	3-5/16	-3/4
MDT-5	8	11	10	5-5/8	10-5/8	27-1/4	4-3/8	-3/4
MDT-5	10	11	10	5-5/8	10-5/8	28-1/4	5-3/8	-3/4
MDT-5	12	11	10	5-5/8	10-5/8	32-5/8	6-3/8	1
MDT-5	14	11	10	5-5/8	10-5/8	33-1/8	7-3/8	1

The full port ball valve with a properly selected automatic actuator is recognized by many experts in the industry as the ideal valve type for minimizing surges on pump start-up, shutdown and loss of power. In addition, the installed cost is often lower than other valve types and operating cost savings are lower than virtually all other valve types.

## LOWER INSTALLATION COST

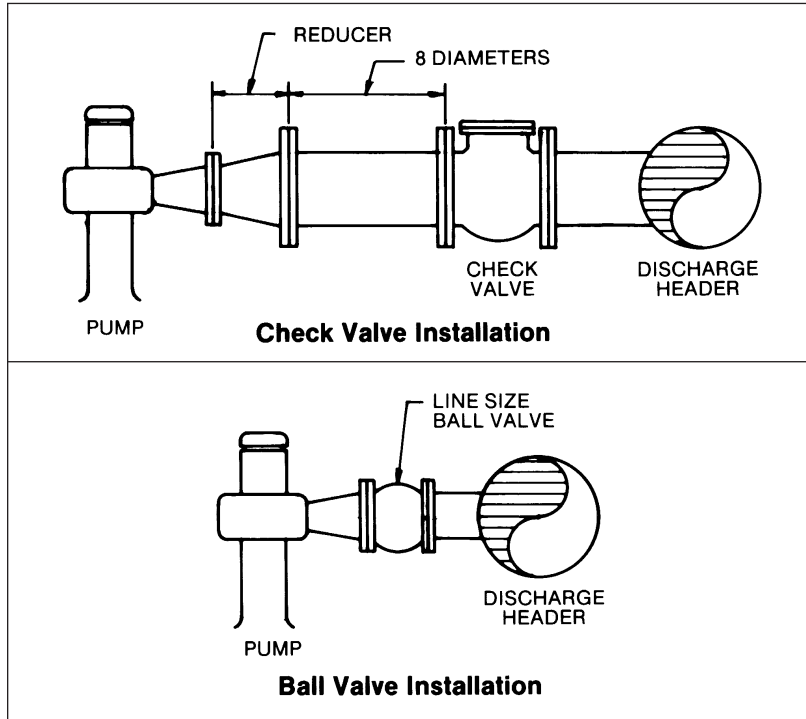

Center post and swing check valves have limitations based on maximum/minimum velocity and turbulence while efficient pump design has high exit velocities and considerable turbulence. The designer, therefore, must use an increaser on the pump discharge nozzle or specify a large discharge nozzle to accommodate the check valve. Additionally, some types of check valves require approximately 8 diameters of unrestricted pipe on the inlet side to ensure proper operation.

The Pratt ball valve does not have these restrictions and, therefore, the piping and building size can be smaller and less expensive.



*Rubber Seated Ball Valve Installation*

## LOWER OPERATING COST

While center post, swing and globe-type check valves may cost less initially, their high operating cost in terms of energy usage continue for the life of the plant as table below indicates.

Because of their full port area, ball valves minimize pumping costs. Annual power costs in dollars can be calculated.

$$\text{Cost} = \frac{\text{QHRT}}{(5810) (e)} \left( \frac{Q}{Cv} \right)^2$$

Q = Flow Rate, gpm  
 H = Head Loss, Feet of Water Column  
 R = Electric Rate, \$/KWHR  
 T = Yearly Use, Hours  
 e = Pump Efficiency

$$H = 2.33 \left( \frac{Q}{Cv} \right)^2$$

Annual costs are summarized below for commonly used values based on 75% use, 8 feet per second flow, 8/KWHR and 80% efficiency.

Annual Operating Costs, Dollars						
VALVE SIZE	PRATT BALL VALVE	BUTTER-FLY VALVE	PLUG VALVE	GLOBE VALVE	SWING CHECK	TILT CHECK
8	\$ 6	\$ 97	\$135	\$718	\$140	\$ 85
12	13	142	305	1800	318	190
16	24	252	540	2900	570	340
24	53	383	1220	6200	1300	760
30	83	600	1900	-	2000	1200
36	120	350	2750	-	2800	1700

Pratt Ball Valve Cv Full Open			
Valve Size	Cv	Valve Size	Cv
6	5250	24	84000
8	9330	30	131300
10	14600	36	189000
12	21000	42	257300
14	28600	48	336000
16	37300	54	425300
18	47300	60	525100
20	58300		

## TYPICAL PUMP/CHECK SURGE CONTROL SYSTEM

The Pratt pump/check surge control system employs a Pratt ball valve with appropriate operator and controls to achieve tight shut-off in all applications. This is particularly desirable in waste water applications where tight shut-off is necessary to afford best possible working conditions downstream. This system is designed to minimize hydraulic shock within the piping system on both pump start and stop and is inherently reliable and maintenance free for long periods. The system consists of the ball valve with cylinder operator and limit switches and a hydraulic control panel. The control system may also include a pump start-pushbutton station.

Operating characteristics of the system include provision for adjustment of normal opening speeds from 60 to 300 seconds, and normal closing speeds from 60 to 300 seconds, and of emergency closure speeds from 10 to 30 seconds. This range of speeds normally provides adjustment capable of eliminating

excessive hydraulic shock in normal opening and closing modes.

The Pratt ball valve provides generally the same closure characteristics as other valve types used in pump check service, and like all of these valves its full stroke closing and opening time is the major factor in calculation of water hammer. Pratt suggests installation of surge relief protection in any system that has an emergency closure provision.

Operating with pressures from 40 to 150 psig, the Pratt system uses water, air or oil as an operating medium. While electrically powered solenoids control normal operation, the system is designed to automatically provide emergency closure with control circuit power failure. Manual override is possible at any time – with or without electrical power.

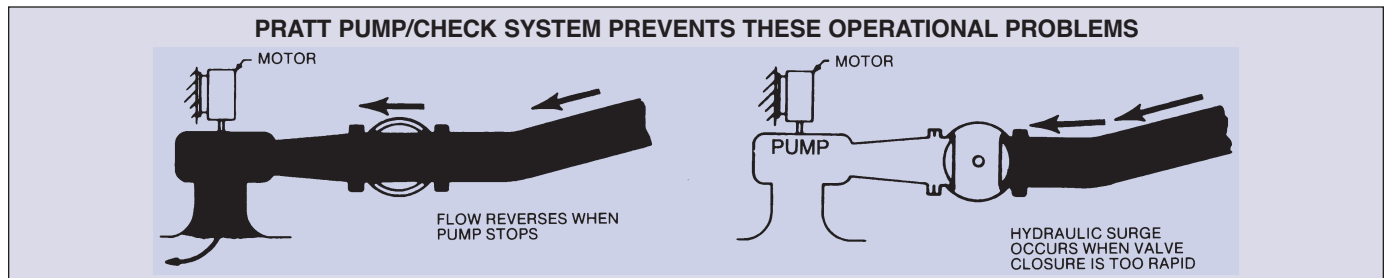

## DETAILS OF OPERATION

### Normal Pump Start

In this mode, the pump motor circuit is energized, thereby starting the pump. As the pump comes up to speed, or design head, three alternative methods are used to signal the Pratt pump/check valve.

**Single Pressure Switch** – The pressure switch is tapped off the upstream side of the pump/check valve. When the discharge pressure of the pump reaches a preset level, the pressure switch trips, energizing the solenoid circuit to the four-way valve, opening the pump/check valve.

**Time Delay Relay** – This electrical device is part of the pump/motor circuit. Once the pump motor circuit is active the time delay relay is energized which is preset to initiate the four-way valve circuit causing the Pratt pump/check valve to open. The amount of time delay is related to the type of pump and the time it takes for the pump to come up to speed.

**Differential Pressure Switch** – This pressure switch is tapped off the downstream and upstream sides of the Pratt pump/check valve. As soon as the pump/motor circuit is energized, the differential pressure switch is able to sense when the pump discharge pressure is greater than the downstream pressure, and trips the switch, closing the four-

way valve circuit and causing the Pratt pump/check valve to open. During pump start, the two-way solenoid valves are continuously energized and remain energized while the pump is on line.

### Normal Pump Stop

This mode of operation is selected when the pump is taken off line for reasons of demand, maintenance, etc., For normal close the four-way valve circuit is de-energized, causing the Pratt pump/check valve to close. (The two-way solenoid emergency bypass valves remain energized during normal pump stop.) While the Pratt pump/check valve moves toward the closed position the pump/motor set continues to run. The pump/motor circuit is tripped off by a limit switch on the Pratt pump/check ball valve. The point at which the limit switch trips out the pump/motor circuit relates to concerns of hydraulic surge in the system, pump speed, etc. However, for some installations the pump/motor circuit is tripped out prior to the Pratt pump/check valve reaching the full closed position. On some systems the Pratt pump/check valve is fully closed prior to tripping out the pump/motor circuit. The settings of the limit switch that trips out the pump/motor circuit are normally made in the field.

When the pump/motor circuit is tripped out, the two-way solenoid emergency bypass circuit can be de-energized.

# TYPICAL PUMP/CHECK SURGE CONTROL SYSTEMS

## Emergency Closure

This mode of operation usually occurs when an electric power failure causes the pump/motor set to stop. In an incident of this nature the Pratt pump/check ball valve must close at a rate more rapid than normal closure rates. The need for rapid closure of the Pratt pump/check valve is to prevent a high reverse flow rate which can backspin the pump and cause damage to the pump/motor set and drain the system stored water.

On total electric power failure the four-way valve and the two-way bypass emergency valves are de-energized. The bypass piping circuit parallels the four-way valve circuit and provides a larger cylinder supply flow rate to the Pratt pump/check valve cylinder operator resulting in rapid closure. If the pump/check ball valve has the feature of emergency closure, it is recommended that the pumping system piping should include surge relief devices.

## Typical Control Function

### Normal Pump Start

- Turn selector switch to "On" position.
- Press pump start button starting pump motor.
- When pump comes up to desired head, the pressure switch closes, energizing the four-way valve circuit, causing the Pratt pump/check valve to open.

### Normal Pump Stop

- Turn selector switch to "Off" position. This de-energizes four-way valve circuit causing the Pratt pump/check valve to close.
- When the Pratt pump/check valve reaches 75% to 95% close, the momentary limit switch trips, de-energizing the pump/motor circuit and shutting down the total system.

### Emergency Closure

All circuits are de-energized simultaneously allowing rapid closure through the two-way valve bypass piping.

On pump/check service, ball valve starts to open only after pump has reached desired speed (or pressure). When fully open, ball provides full circular waterway with no more pressure drop than an equivalent length of pipe.

If power loss to pump occurs, valve closes at desired speed to prevent reversal of flow toward pump. Upon complete closure, valve is bubble-tight against back flow towards the pump.

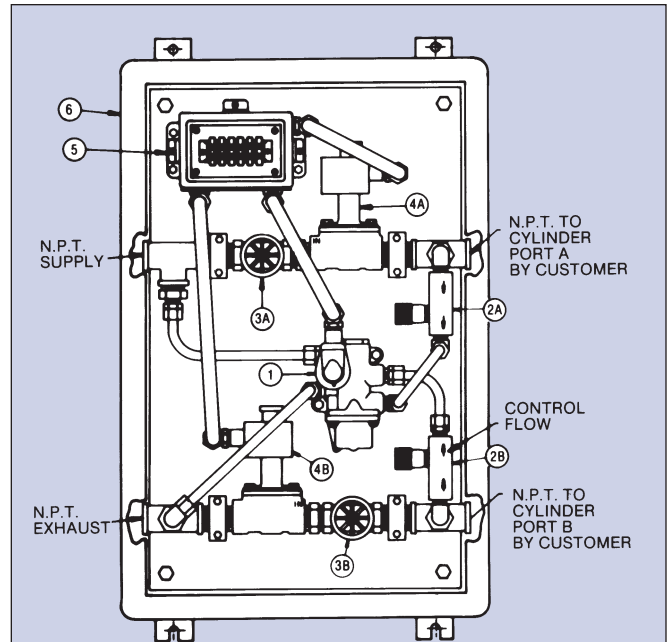

### Equipment Furnished

- |  |   |
|--|---|
| 1 — Two-Position Single Solenoid 4-Way Valve Manual Operator         | 4A & 4B — Single Solenoid 2-Way Valve (Normally Open) |
| 2A & 2B — Adjustable Flow Control (Normal Operations)                | 5 — NEMA Type IV Terminal Box with Terminal Block     |
| 3A & 3B — Balance and Stop Valve (Emergency Flow Control & Shut-Off) | 6 — NEMA Type XII Single Door Control Cabinet         |

### Hydraulic Schematic

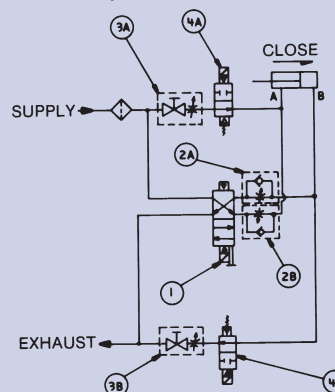

### Typical Electrical Schematic

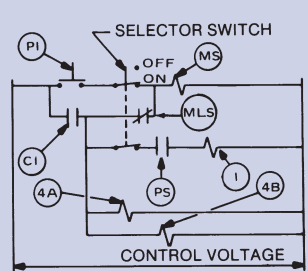

- C1 — Motor Starter Holding Contact
- P1 — Pump Start Button
- MS — Motor Starter Solenoid
- MLS — Momentary Limit Switch
- 1 — 4-Way Valve Solenoid Coils
- PS — Pressure Switch Contacts
- 4A, 4B — Emergency 2-Way Valve Solenoid Coils

## CONTROL APPLICATIONS

The ball valve has proven very effective in a wide variety of control valve applications – pressure reducing, pressure sustaining, system balancing, flow control, etc.

The basic structure of a full port ball valve has a flow path that extends its capabilities beyond that of a standard plug valve or butterfly valve. The ball in the throttled position has the effect of two plugs or discs to absorb the energy of the flowing media. Consequently, the ball valve's flow range and throttling capabilities are extended beyond that of a single plug or butterfly valve.

In addition, Pratt has standard control systems for most applications and a staff of experienced engineers to assist you in the design of special systems.

In applications with severe throttling where cavitation can be a problem, Pratt has designed many systems to eliminate or minimize cavitation and has patented integral anti-cavitation devices that solve the majority of these problems.

## CHARACTERIZED CLOSURE

The chart below shows the relationship of ball valve ball angle to percent of full flow area. Also shown is similar data for a butterfly valve and plug valve. The ball valve has noticeably smaller slope approaching the closed position, producing a smaller change in unit flow per unit time at closure. This characteristic combined with characterization that may be available from the operator has a beneficial effect in reducing water hammer. However, principal means of controlling water hammer remains in limiting speed of valve closure.

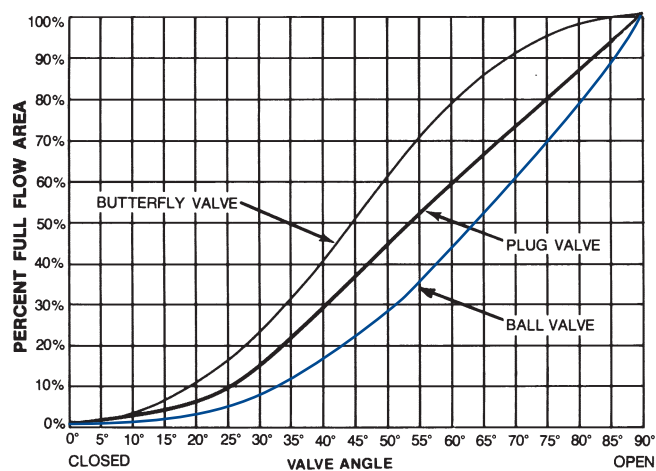

## SHUTOFF/BLOCK VALVE SERVICE

The ball valve is an excellent block valve. In the full open position, the pressure drop is the same as an equivalent length of pipe. In the shut position, the Pratt ball valve gives consistent drop-tight shutoff. The Pratt rubber seated ball valve has no metal-to-metal contact surfaces and, therefore, requires no exercising and is easily operated by one person even after extended periods of time.

Because the Pratt ball valve is full ported and has high flow capabilities, many users combine it with a pair of reducers in a smaller than line size configuration. In these installations, the pressure loss is equivalent to the loss of a pair of reducers which in many cases is still less than the pressure loss through other types of line size valves.

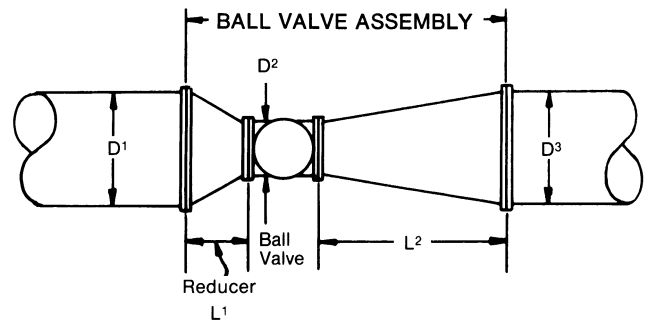

Computer generated head loss data can be provided.

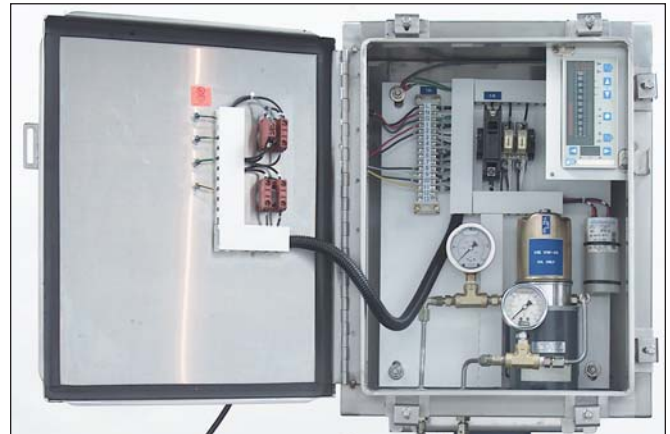

Typical Flow or Pressure Control System

Pratt History >

Engineering >

Products >

Specifications >

<http://www.henrypratt.com/>

### PRATT PRODUCT GUIDE

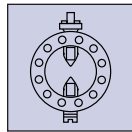

Model 2FI

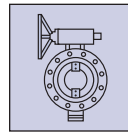

Triton® HP250

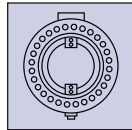

Triton® XR70



Control Systems

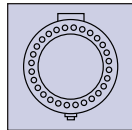

Triton® XL

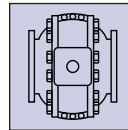

Metal Seated Ball Valve

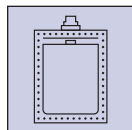

Rectangular

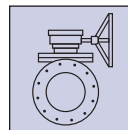

Plug Valve

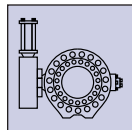

Rubber Seated Ball Valve

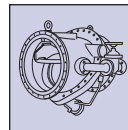

Tilting Disc Check Valve

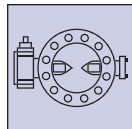

Groundhog® Valve

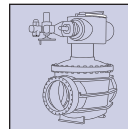

Cone Valve

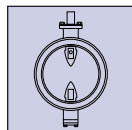

Monoflange MKII

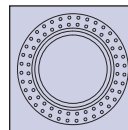

Sleeve Valve

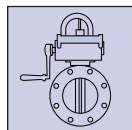

Indicating Butterfly Valve  
UL & FM approved

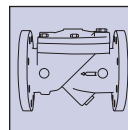

Check Valve

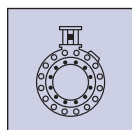

N-Stamp Nuclear Butterfly Valve

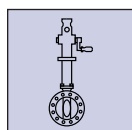

PIVA Post Indicating Valve Assembly  
UL & FM approved



#### Henry Pratt Company

401 South Highland Avenue  
Aurora, Illinois 60506-5563  
Toll Free 877-436-7977  
630-844-4000  
Fax 630-844-4160  
www.henrypratt.com  
ISO 9001: 2000 Certified

©2006 Henry Pratt Company  
Printed in the U.S.A.  
BALL-0906

