

PRATT

Henry Pratt Company

Sleeve Valves

Energy Dissipaters



Valves for the 21st Century



A Tradition of Excellence

With the development of the first rubber seated butterfly valve more than 70 years ago, the Henry Pratt Company became a trusted name in the flow control industry, setting the standard for product quality and customer service. Today Pratt provides the following range of superior products to the water, wastewater and power generation industries.

BUTTERFLY VALVES: from 3" to 162"

RECTANGULAR VALVES: 1' x 1' to 14' x 16'

BALL VALVES —

RUBBER SEATED: from 4" to 60"

METAL SEATED: from 6" to 48"

PLUG VALVES: from 1/2" to 36", 3 ways

HYDRAULIC CONTROL SYSTEMS

VALVE CONTROLS

**ENERGY DISSIPATING VALVES
AND FIXED ENERGY DISSIPATERS**

CONE VALVES

CHECK VALVES

A Commitment to Meeting The Customers' Needs

Henry Pratt valves represent a long-term commitment to both the customer and to a tradition of product excellence. This commitment is evident in the number of innovations we have brought to the industries we serve. In fact, the Henry Pratt Company was the first to introduce many of the flow control products in use today, including the first rubber seated butterfly valve, one of the first nuclear N-Stamp valves, and the bonded seat butterfly valve.

Innovative Products For Unique Applications

Though many of the standard valves we produce are used in water filtration and distribution applications, Pratt has built a reputation on the ability to develop specialized products that help customers to meet their individual operational challenges.

Creative Engineering for Fluid Systems

Pratt's ability to provide practical solutions to complex issues is demonstrated by the following case histories.

Earthquake Proof Valves

Pratt designed and manufactured hydraulically actuated valves for a water storage application so that the valves would automatically operate in the event of earthquakes. This led to the development of a valve that will withstand forces of up to 6g's.

Custom Actuation/ Isolation Valves

Pratt designed and manufactured valves that would isolate a working chamber in the event of a nuclear emergency during the decommissioning of armed nuclear warheads. The valves were able to close in a millisecond using specially designed Pratt electro-pneumatic actuators.

Valves Designed for Harsh Environments

Pratt designed and manufactured a 144" diameter butterfly valve for the emergency cooling system at a jet engine test facility. The valve was designed to supply water to help dissipate the tremendous heat generated by the engines during testing.

PRATT

Henry Pratt Company

Through experience, commitment and creative engineering, Pratt is uniquely suited to provide superior products for our customers' special needs. For more information, contact our corporate headquarters in Aurora, Illinois.

PRATT

Henry Pratt Company

401 South Highland Avenue
Aurora, Illinois 60506-5563
www.henrypratt.com
phone: 630.844.4000
fax: 630.844.4160
toll free: 877.436.7977



SLEEVE VALVES

TABLE OF CONTENTS

INTRODUCTION TO ENERGY DISSIPATING VALVES.....	1
SCOPE OF THE LINE: MODEL 711	1
CAVITATION CONTROL ADVANTAGE.....	1
PRECISION FLOW CONTROL	2
FEATURES AND BENEFITS	2
SLEEVE VALVE APPLICATIONS	3
ENERGY DISSIPATER DEVICE MODEL 211	4
MODEL 711 VALVE SPECIFICATIONS.....	4
SLEEVE VALVE SIZING CHART.....	5
SLEEVE VALVE ED DETERMINATION CHART	6
DRAWINGS	7-8
EXAMPLES SIZING AND DETERMINING MODEL NUMBER	8

INTRODUCTION TO ENERGY DISSIPATING VALVES



Over the years, Pratt has maintained a commitment to product innovation by designing water control valves that improve our clients' processes and reduce their operation and maintenance costs. Our products are developed to meet and surpass even the most difficult specifications.

By adding sleeve valves, fixed cone valves, and energy dissipaters to our product line, Pratt continues to expand our offering to those customers who require specialty valves for applications where there is zero or low back pressure, cavitation or high flow rates.

SCOPE OF THE LINE: MODEL 711 AXIAL FLOW MULTIJET SLEEVE VALVE



Water jets striking each other instead of the valve walls

- Available in sizes 12 inches and larger
- Fabricated steel construction
- 304 or 316 stainless steel sleeve
- Tapered radial nozzles
- Stainless steel drive screws
- Stainless steel gate with Nitronic 60 inserts



Nozzle pattern on the valve sleeve

CAVITATION CONTROL ADVANTAGE

The Model 711 Sleeve Valve is used to reduce and regulate pressure and control flow. Designed specifically to dissipate energy, the Model 711 controls the point of cavitation, but does not eliminate cavitation completely.

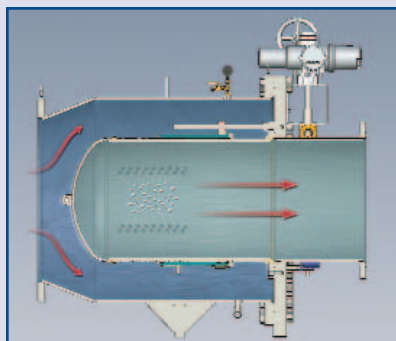

Model 711 Cross Section

The stainless steel sleeve and innovative nozzle pattern balance the fluid forces in the valve. The water jets strike each other instead of the valve walls preventing damage.

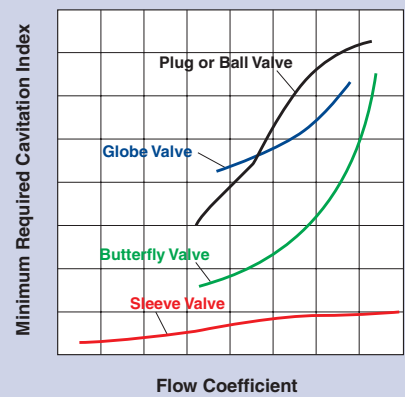

Cavitation Index Curve

PRECISION FLOW CONTROL

The Model 711 sleeve valve provides a flow coefficient with a nearly constant rate of change, allowing precise flow control over the entire stroke of the valve. The chart below illustrates the near linear flow characteristic of the Pratt sleeve valve.

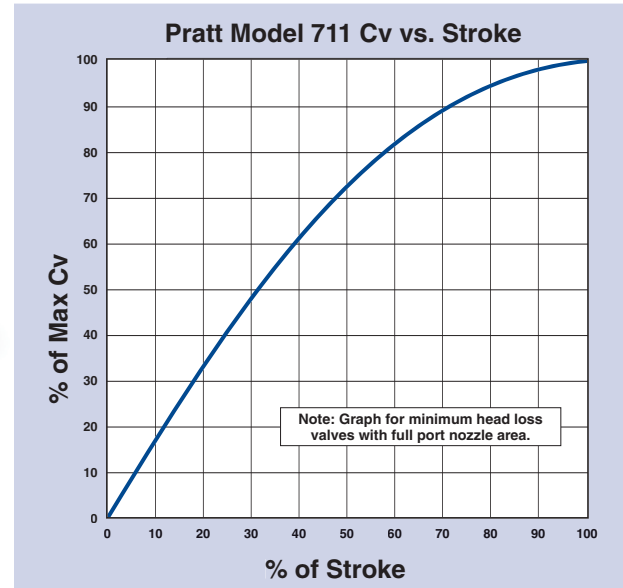
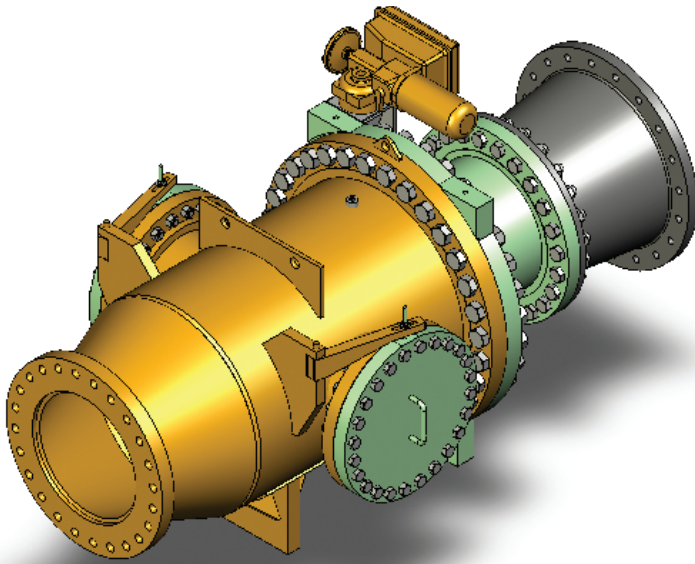

Pratt Model 711 Cv vs. Stroke

FEATURES AND BENEFITS: MODEL 711 SLEEVE VALVE

FEATURE

- External seat on sleeve
- Opposing tapered nozzle pattern
- Linear flow pattern
- Large access ports

BENEFIT

- Provides drip tight shut off
- Balances the fluid forces and minimizes vibration
- Water flows through the nozzles and dissipates energy
- Allows precise flow control over the stroke of the valve
- Maintenance can be performed while the valve is in line

SLEEVE VALVE APPLICATIONS

Reservoir Discharge

Pratt sleeve valves are used to control flow and dissipate excess energy from a reservoir outlet. Commonly used in areas with a high pressure drop, the sleeve valve can discharge to the atmosphere, or to a submerged outlet in a downstream creek.

Pump Control

Sleeve valves can be designed to have lower pressure drops than other types of control valves. Because the valve has a near linear flow characteristic, it will cycle less often thus minimizing energy loss and reducing operational costs over the life of the valve.

Pressure Regulation

A sleeve valve can be used to reduce pressure from a high pressure supply to a lower pressure distribution zone. Typically a SCADA system controls the valve position.

Turbine Bypass

When a valve is needed to bypass an energy recovery turbine, a sleeve valve can minimize upstream and downstream pressure surges by slowly opening and closing in proportion with the turbine.

Tank Level Control

Sleeve valves are ideal to control the water level in a distribution system storage tank in potable water applications.



36" Model 711 Inline Sleeve Valve

ENERGY DISSIPATER DEVICE

The energy dissipater device uses the same technology as the Multi-Jet Sleeve Valve. The energy dissipating mechanism forces the high pressure water through specially tapered nozzles that cause the water to form jets which impact each other in the center of the sleeve, providing energy dissipation with smooth operation.

Model 211 Inline Fixed Sleeve Energy Dissipater

The Model 211 is used in transmission lines to restrict the discharge of fluid in a line break. They are also used to prevent excess velocities due to high line pressure.

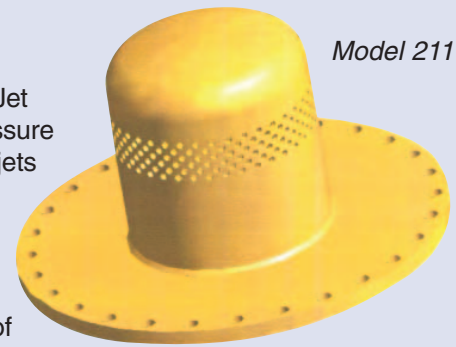

Model 211

Consult the factory for more information.

SUGGESTED SPECIFICATION FOR MODEL 711 SLEEVE VALVE

General

The valve shall be of the Axial Flow (Inline) Multi-Jet type Sleeve Valve as manufactured by the Henry Pratt Company or approved equal.

Design

The valve shall be designed to operate throughout its flow range without damaging cavitation for the conditions specified. The design shall incorporate multiple tapered nozzles on the sleeve for controlling flow and reducing pressure. These nozzles shall be arranged in a pattern which effectively directs the water streams to collide at the center of the downstream discharge pipe. The valve shall be capable of regulating flow by the linear movement of the sleeve gate which exposes the required amount of nozzles to achieve the correct flow rate. Valves shall be capable of dissipating energy thus enabling them to be opened against high differential head without damaging the seals.

Valve Body

The valve body shall be flanged on both the upstream and downstream ends conforming to applicable standards for bolting into the system conduit. The body section and flanges shall be carbon steel or other specified materials. The body shall have an integral clean out port, sized as required and situated in line with the sleeve for debris removal. Lifting eyes should also be attached to the body for ease of installation.

Sleeve

The sleeve shall be constructed of 304 or 316 stainless steel which shall contain the tapered nozzles. The size and quantity of the nozzles shall be determined by the flow and pressure requirements to meet the application for which it is intended.

Sleeve Gate

The sleeve gate shall be manufactured of stainless steel 304 with Nitronic 60 inserts, providing long life, non-galling operation.

Actuators

The sleeve valve shall be capable of being operated by pneumatic or hydraulic cylinders, electric motor actuators or manual gear actuators.

Testing

The valve shall be hydrostatically tested in the open position at a pressure equal to two times the working pressure for a period of not less than 30 minutes. A seat leak test shall be performed at the working pressure with the valve in the closed position, for a minimum of 15 minutes. The valve shall be cycled from closed to open three times for operational testing.

Options

Isolation valves are recommended for all sleeve valves so that debris removal can be achieved. Considerations should be given to placement of isolation valves if not full port. Consult factory for recommendations.

SLEEVE VALVE SIZING

THE STEPS:

See examples last page of brochure.

- Based on the site specific conditions for the application being considered determine:
 - the required maximum flow rate (Qmax), 2) the minimum dynamic inlet pressure (P1), at this flow rate, and 3) the outlet pressure (P2) required.
- Using Table 1, pick the smallest sleeve size with an available flow rate that exceeds the (Qmax) flow rate required.
- Next calculate the application Cv from (Qmax) and the application pressure differential (P1 – P2) determined in Step 1. (i.e. $Cv = Q_{max}$ in gpm / $\sqrt{(P1-P2)}$ in psi). For convenience use flow and pressure units that match those listed in Table 2. Finally, include a flow safety factor, thus the calculated application Cv x 1.2 provides the Cv required or Cv(reqd).
- Using Table 2, check if the sleeve size chosen in Step 2 has an available Cv equal to or greater than Cv(reqd) calculated in Step 3. If so, your sleeve valve size has been determined. If not, choose a larger sleeve size that exceeds the Cv(reqd) value.
- Check Table 3 to see if a second stage Energy Dissipater should be considered. For valves utilizing an additional Energy Dissipater, a Model 712 is provided. For less severe applications, a Model 711 is recommended.
- Use Table 4 for Model 711 valves, and Tables 4 and 5 for Model 712 valve applications, to find the approximate laying length of the valve. Factors affecting the final laying length depend on the sleeve size vs. mating pipe size. A variety of body styles are shown in Table 4 to accommodate various valve installations.
- Contact Henry Pratt Sales to optimize and verify your initial selection.

TABLE 1

Nominal Sleeve Diameter		Maximum Available Flow Rates				
in	mm	cfs	gpm	mgd	m3/s	l/s
12	300	25.1	11,310	16.2	0.71	711.8
14	350	34.2	15,394	22.1	0.97	968.8
16	400	44.7	20,106	28.9	1.27	1,265.4
18	450	56.5	25,447	36.5	1.60	1,601.5
20	500	69.8	31,416	45.1	1.98	1,977.1
24	600	100.5	45,239	65.0	2.85	2,847.0
30	750	157.1	70,686	101.5	4.45	4,448.5
36	900	226.2	101,788	146.2	6.41	6,405.8
42	1100	308.7	138,529	199.5	8.74	8,739.8
48	1200	402.1	180,956	259.9	11.39	11,388.2
54	1400	508.9	229,023	328.9	14.41	14,413.2
60	1500	628.3	282,744	406.1	17.79	17,794.0

TABLE 2

Nominal Sleeve Diameter		Maximum Available Flow Coefficients				
		cfs/ \sqrt{ft}	Cv=gpm/ $\sqrt{\Delta psi}$	mgd/ $\sqrt{\Delta psi}$	(m ³ /s)/m	(l/s)/m
12	300	3.97	2,717	3.91	0.20	204
14	350	5.41	3,698	5.33	0.28	277
16	400	7.06	4,830	6.96	0.36	362
18	450	8.94	6,113	8.80	0.46	458
20	500	11.03	7,547	10.87	0.57	566
24	600	15.89	10,868	15.65	0.82	815
30	750	24.83	16,981	24.45	1.27	1,274
36	900	35.75	24,453	35.21	1.83	1,834
42	1100	48.81	33,268	47.90	2.50	2,503
48	1200	63.56	43,472	62.60	3.26	3,260
54	1400	80.44	55,019	79.23	4.13	4,126
60	1500	99.31	67,925	97.81	5.09	5,094

PROCEDURE FOR SECONDARY ED DETERMINATION

For some applications, a two stage valve will be needed. The Model 712 with the Energy Dissipater (ED) is the extreme application solution.

1. Choose a sleeve size (see sleeve valve sizing steps).
2. Using Table 3, find the intersection of the maximum differential pressure across valve at maximum flow rate and the minimum available downstream/back pressure for your application. If this point lies below the line for the sleeve size chosen, then no ED is required. If the point is above the line for the sleeve size chosen, then an ED may be required.
3. If the point is above the line for the sleeve chosen but the downstream pressure is above 20 psi an ED may not be required.
4. Contact the factory for a detailed analysis.

Table 3

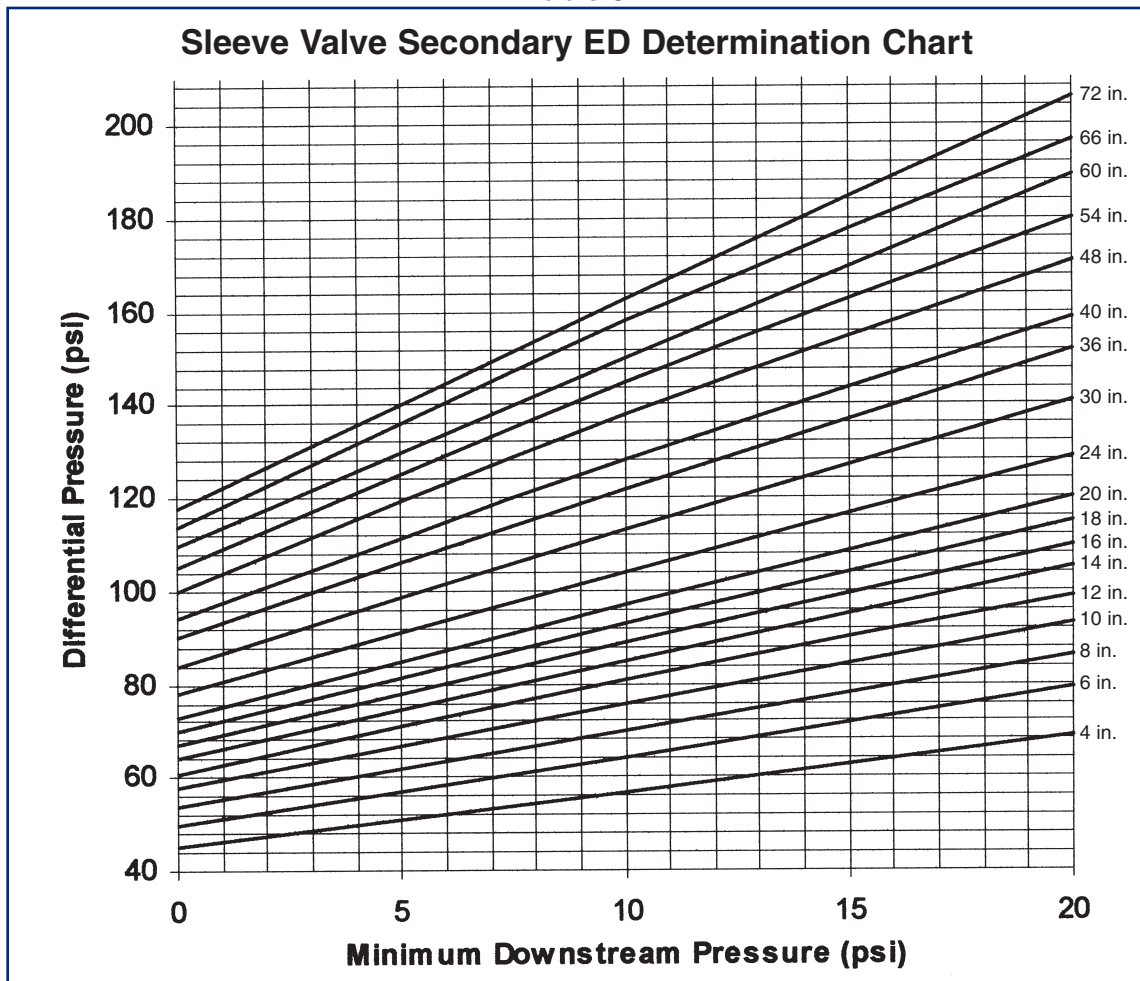

To determine the cavitation constant, use the following formula:

$$C = \frac{P_2 - P_v}{P_1 - P_2} = \frac{P_2 + 14.2}{\Delta P}$$

C = Cavitation constant; dimensionless

Ccr = .15 to .25

P₁ = Upstream head; psi

P₂ = Downstream head; psi

ΔP = P₁ - P₂ = Head loss across valve; psi

P_v = Adjusted water vapor pressure (-14.2 psi) at sea level

If C ≤ Ccr, serious cavitation can occur.

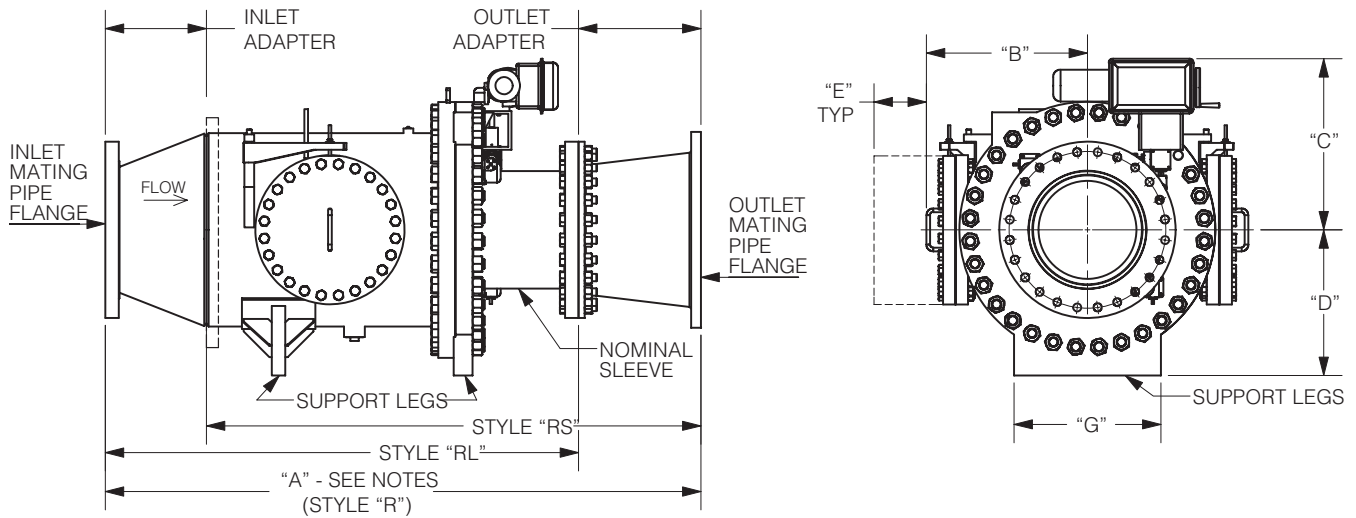

NOTES:

1. DIMENSIONS WILL VARY DEPENDING ON ACTUAL APPLICATION AND MATING PIPE SIZE.
2. MOTOR ACTUATED VALVE IS SHOWN AND RECOMMENDED, FOR OTHER ACTUATOR TYPES THE OVERALL VALVE LENGTH WILL INCREASE. CONTACT HENRY PRATT SALES.
3. THE TYPE 711 INLINE SLEEVE VALVE CAN BE FURNISHED IN 3 BODY STYLES DEPENDING ON THE MATING PIPE DIA. NOTE THAT BODY STYLE "R" DIM'S ARE SHOWN IN THE TABLE.
4. UPSTREAM AND DOWNSTREAM ISOLATION VALVES ARE RECOMMENDED. FOR PLACEMENT AND TYPE CONTACT HENRY PRATT SALES. DOWNSTREAM ISOLATION VALVE IF NOT FULL PORT SHOULD BE PLACED A MINIMUM OF 10-15 PIPE DIA'S DOWNSTREAM
5. ADEQUATE STRAIGHT INLET AND OUTLET PIPING SECTIONS ARE REQUIRED. KEEP PIPING ELBOWS, TEES, ETC. SUFFICIENT DISTANCE FROM VALVE. CONTACT HENRY PRATT SALES.

INLET/OUTLET ADAPTER NOTES

1. INLET ADAPTER LENGTH VARIES CONSIDERABLY BASED ON MATING PIPE TO SLEEVE RATIO. CONTACT HENRY PRATT SALES.
2. OUTLET ADAPTER LENGTH CAN BE ESTIMATED AT APPROXIMATE 1 OUTLET MATING PIPE DIA.

SLEEVE VALVE BODY STYLES

- STYLE "R" = MATING PIPE AS NOTED.
 STYLE "RL" = MATING PIPE AND SLEEVE SIZE EQUAL.
 STYLE "RS" = MATING PIPE EXCEEDS TYPE R.

TABLE 4, Model 711 General Dimensions (Body Style "R")

STYLE "R" Mating Pipe Dia's	STYLE "RL" Mating Pipe Dia's	Nominal Sleeve Diameter		A		B		C		D		E		G		Estimated Weight	Estimated Lbs.
		IN	MM	SEE NOTE 1	SEE NOTE 1	IN	MM	IN	MM	IN	MM	IN	MM	IN	MM		
SEE NOTE 1																	
14 to 20	12	12	300	85	2159	23	578	44	1111	20	502	27	686	18	506		7,500
16 to 24	14	14	350	90	2286	25	635	46	1168	22	559	27	686	20	507		7,800
18 to 24	16	16	400	94	2388	27	695	48	1229	24	619	27	686	22	508		8,200
20 to 30	18	18	450	110	2794	32	813	53	1346	29	737	32	813	24	584		8,500
24 to 36	20	20	500	115	2921	33	848	54	1381	30	772	32	813	26	635		8,700
30 to 36	24	24	600	125	3175	33	848	54	1381	30	772	32	813	30	762		9,000
36 to 48	30	30	750	150	3810	42	1070	63	1603	39	994	32	813	36	965		9,400
42 to 54	36	36	900	165	4191	46	1156	67	1689	43	1080	32	813	42	1143		10,500
48 to 60	42	42	1100	195	4953	49	1245	70	1778	46	1168	32	813	48	1346		12,000
54 to 66	48	48	1200	220	5588	52	1327	73	1861	49	1251	42	1067	54	1524		16,000
60 to 72	54	54	1400	240	6096	59	1495	80	2029	56	1419	42	1067	60	1727		20,000
72 to 96	60	60	1500	260	6604	62	1581	83	2115	59	1505	42	1067	66	1905		25,000

TABLE 5, Model 712 (Sleeve Valve with ED) (Add “AA” and “A” for overall length)

Minimum Upstream Pipe		Nominal ED Sleeve Diameter		ED Length AA	
in	mm	in	mm	in	mm
12	300	12	300	18	450
14	350	14	350	21	550
16	400	15	400	24	600
18	450	18	450	27	700
20	500	20	500	30	750
24	600	24	600	36	900
26	660	26	660	39	1000
30	800	30	800	45	1150
36	900	36	900	54	1400
42	1100	42	1100	63	1600
48	1200	48	1200	72	1850
54	1400	54	1400	81	2050
60	1500	60	1500	90	2300

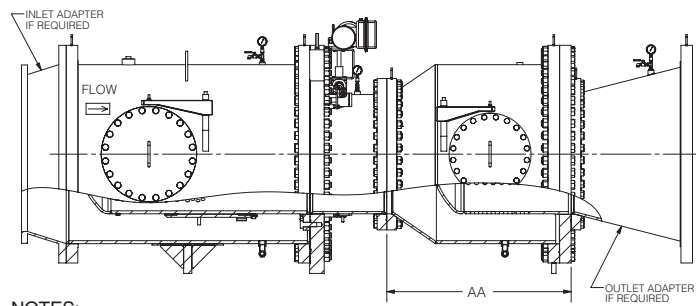

NOTES:

1. THIS DIAGRAM SHOWS A VALVE REQUIRING AN ENERGY DISSIPATER (ED). THE ED IS TYPICALLY FITTED TO A STANDARD SLEEVE VALVE, OR CAN BE A SEPARATE DOWNSTREAM MODEL 211 UNIT. ADD THE ED LENGTH TO A STANDARD VALVE TO GET AN APPROXIMATE OVERALL VALVE LENGTH. NOTE THAT ACTUAL VALVE LAYING LENGTH WILL VARY DEPENDING ON WHICH STANDARD VALVE BODY STYLE IS USED AND PIPING INSTALLATION.
2. UPSTREAM AND DOWNSTREAM ISOLATION VALVES ARE RECOMMENDED. FOR PLACEMENT AND TYPE CONTACT HENRY PRATT SALES. DOWNSTREAM ISOLATION VALVE IF NOT FULL PORT SHOULD BE PLACED A MINIMUM OF 10-15 PIPE DIA'S DOWNSTREAM.
3. ADEQUATE STRAIGHT INLET AND OUTLET PIPING SECTIONS ARE REQUIRED. KEEP PIPING ELBOWS, TEES, ETC. SUFFICIENT DISTANCE FROM VALVE. CONTACT HENRY PRATT SALES.

Examples Sizing and Determining Model Number

Example 1: Known: A flow control valve is needed for the inlet of a treatment plant. The dynamic inlet head is 20 psi, the desired outlet pressure is 10 psi, a flow rate of 10 cfs is desired, a maximum velocity of 12 fps is allowed in the mating piping. Solution: Using 12 fps velocity, the size of the mating piping is found to be 12 inches. For the sleeve valve, checking available flow only per Table 1, an 8 inch sleeve is the smallest size exceeding the required flow. Next converting cfs to gpm flow units so that flow/pressure units match those in Table 2, $C_v = (10 \text{ cfs} \times 450 \text{ gpm/cfs}) / \sqrt{(20\text{psi}-10\text{psi})} = 1423$. Thus $C_v(\text{reqd}) = 1423 \times 1.2 = 1,707$. Then using Table 2, the smallest sleeve with a C_v greater than $C_v(\text{reqd})$ is a 10 inch sleeve. Using the 10 inch sleeve size and checking Table 3, the maximum differential pressure is below the line for the 10 inch valve at the minimum down stream pressure, so no ED is required, thus a model 711. Use Table 4 to find the approximate dimensions of the valve. In this case the Model Number will be a Model 711 – 12x10x12 (Model No. - Inlet x Sleeve x Outlet).

Example 2: Known: A valve is needed to reduce the pressure of water being taken from a high elevation distribution system to a lower elevation distribution system. The dynamic inlet pressure at the sleeve valve will be 250 psi, the downstream pressure will be 0 psi because the valve will be filling a large trunk line to a ground reservoir a few feet below the valve vault, the desired flow rate is 45,000 gpm, the maximum velocity in the mating pipe is limited to 15 fps. Solution: Using 15 fps velocity, the size of the mating piping is found to be 36 inches. For the sleeve valve, checking available flow only per Table 1, a 24 inch sleeve is the smallest size exceeding the required flow. The calculated C_v is $45000\text{gpm} / \sqrt{(250 \text{ psi} - 0 \text{ psi})} = 2846$. Thus $C_v(\text{reqd}) = 2846 \times 1.2 = 3,415$. Using Table 2, a 14 inch sleeve meets this requirement, however, the flow rate per Table 1 dictates a 24inch is needed, thus the larger of the two criteria must be used. Checking Table 3, with a 24 inch sleeve and a differential of 250 psi, a downstream pressure greater than 0 psi is needed. Therefore an additional second sleeve (ED) is needed, thus a model 712. Add the ED length from Table 5 to the valve length in Table 4 to get the overall valve length. In this case the Model Number will be a Model 712 – 36x24x36.

Example 3: Known: A valve is needed to by-pass a small energy recovery turbine. The dynamic inlet head is 130 psi, the outlet pressure is 10 psi, the maximum flow rate is 140 mgd. Mating pipes are going to be 36 inch. Based on maximum available flow rates in Table 1, a 36 inch sleeve can be used. The required C_v value is $140\text{mgd} / \sqrt{(130 - 10 \text{ psi})} = 12.78$. With the safety factor, $C_v(\text{reqd}) = 12.78 \times 1.2 = 15.34$, and per Table 2 a 36 inch exceeds this. Checking Table 3, a 36 inch sleeve with 120 psi differential, requires a minimum downstream pressure of 9 psi. We have 10 psi indicating no ED is required, however, being so close to the boundary, a second energy dissipater (ED) would be recommended. Using Tables 4 & 5, the dimensions for the valve can be determined. The Model Number will be a Model 712 – 36x36x36.

Pratt History >

Engineering >

Products >

Specifications >

<http://www.henrypratt.com/>

PRATT PRODUCT GUIDE

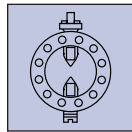

Model 2FI

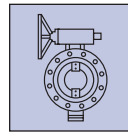

Triton® HP250

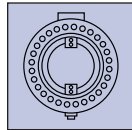

Triton® XR70



Control Systems

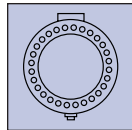

Triton® XL

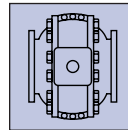

Metal Seated Ball Valve

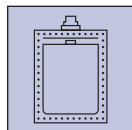

Rectangular

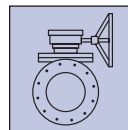

Plug Valve

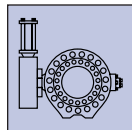

Rubber Seated Ball Valve

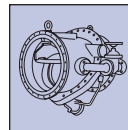

Tilting Disc Check Valve

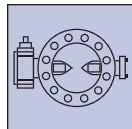

Groundhog® Valve

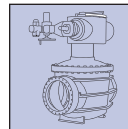

Cone Valve

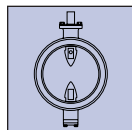

Monoflange MKII

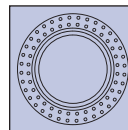

Sleeve Valve

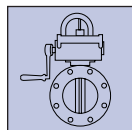

Indicating Butterfly Valve
UL & FM approved

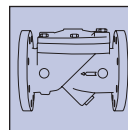

Check Valve

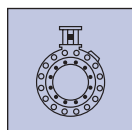

N-Stamp Nuclear Butterfly Valve

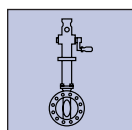

PIVA Post Indicating Valve Assembly
UL & FM approved



Henry Pratt Company

401 South Highland Avenue
Aurora, Illinois 60506-5563
Toll Free 877-436-7977
630-844-4000
Fax 630-844-4160
www.henrypratt.com
ISO 9001: 2000 Certified

©2008 Henry Pratt Company
Printed in the U.S.A.
SV-408

